

Please check the display of your GyroSet™ Cubo



If you **do not see the battery icon**, presenting the battery state of the Vigo, it means you have a system with older device firmwares.

In this case, please carry on reading with the next page.

OR download our mobile application, [GyroSet™ Toolbox](#) and update your system.

If you **see the battery icon**, presenting the battery state of the Vigo, it means you have a system with newer device firmwares.

In this case, please skip to page 52 of this document.

GyroSet™ HEAD DRIVE

USER MANUAL

Document identifier: NOW.Q.CE.M.EN-GS-0002-03

Revision: 03

Date of issue: 01 February 2021

©2021 NOW technologies Ltd. All rights reserved.

NOW technologies, the NOW technologies logo, and the GyroSet™ And Glory names are trademarks of NOW technologies Ltd., registered in 18. Reáltanoda street, Budapest, 1053 Hungary.

European representative of the Manufacturer:

NOW technologies Ltd., 18. Reáltanoda street, Budapest, 1053 Hungary

www.nowtech.hu

You can find step-by-step tutorial videos at

www.nowtech.hu/tutorials/

Table of Contents

Table of Contents	3
User Guide	7
SYSTEM REQUIREMENTS	8
STATEMENT OF THE INTENDED PURPOSE AND USERS	9
Safety and Handling Instructions	9
BATTERIES	9
MEDICAL DEVICE INTERFERENCE	9
SPECIAL SAFETY WARNING	10
Getting Started	11
What's in the box	11
GyroSet™ Vigo	13
GyroSet™ Cubo	14
GyroSet™ LINK	14
GyroSet™ Mouse Application	15
GyroSet™ Drive Application (Available for authorized dealers only)	16
Assembly instructions	17
System connection diagram	17
GyroSet™ Vigo assembly	17
GyroSet™ Link installation	18
GyroSet™ Link Mounting	19
GyroSet™ Link Wiring to PGDT	20
GyroSet™ Cubo Mounting	22
Connecting the GyroSet™ Cubo to the Link and to the Headrest Sensor	23
Headrest and Headrest Sensor	24
Headrest Requirements	24
Jack connector on Cubo	26
How to place the Headrest Sensor on the wheelchair	26
Setting up the System	27
Setting up the Omni and the GyroSet™ Link	27
Programming the Omni	27
Setting up the IOM and the GyroSet™ Link	29
Setting up the Dynamic Controls Linx DLX-IN500 and the GyroSet™ Link	29
Setting up the Quantum Rehab Q-Logic 3 EX Enhanced Display or SCIM Module and the GyroSet™ Link	29

Setting up the Vigo	30
Pairing to your phone (optional: to receive calls and listen to auditory type entertainment)	30
GyroSet™ LINK CONFIGURATION (Available for authorized dealers only)	30
Personalize the driving experience	30
Setting the driving parameters in the OMNI for safe and smooth acceleration	31
How to wear and drive with the GyroSet™ Vigo	33
How to wear the Vigo	33
Turn on the System (for assistants/carers)	34
Driving and mousing with the GyroSet™ Vigo	34
Switch modes with the Vigo	34
Drive mode	34
Mouse mode	35
Switching between available functions	36
Resting	36
Drive with your Vigo	36
Using the OMNI Menu	37
Other GyroSet™ Vigo Functions:	37
Answer and incoming call	37
End a call	37
Reject a call	37
Adjust the volume	37
Play/Pause	37
Power off	37
Battery charging & battery level	38
Music streaming	38
GyroSet™ Vigo Product Specifications	38
Appendix	38
GyroSet™ Vigo LED Indications:	40
GyroSet™ Dongle LED Status Feedback	40
GyroSet™ Link LED (GyroSet™ Logo) Indications:	42
GyroSet™ Link Audible feedback:	43
GyroSet™ Cubo system status feedback	44
SPECIAL SAFETY CHECKLIST	46
WARRANTY	47
Revision History	48
GyroSet™ HEAD DRIVE & MOUSE (New Manual)	52
User Guide	52

SYSTEM REQUIREMENTS	54
STATEMENT OF THE INTENDED PURPOSE AND USERS	54
Safety and Handling Instructions	54
BATTERIES	54
MEDICAL DEVICE INTERFERENCE	55
SPECIAL SAFETY WARNING	55
Getting Started	56
What's in the box	56
GyroSet™ Vigo	58
GyroSet™ Cubo	59
GyroSet™ LINK	59
GyroSet™ Mouse Desktop Application	60
GyroSet™ Drive Desktop Application (Available for authorized dealers only)	61
GyroSet™ Toolbox Mobile Application	62
Assembly instructions	63
System connection diagram	63
GyroSet™ Vigo assembly	63
GyroSet™ Link installation	64
GyroSet™ Link Mounting	65
GyroSet™ Link Wiring to PGDT	66
GyroSet™ Cubo Mounting	68
Connecting the GyroSet™ Cubo to the Link and to the Headrest Sensor	69
Headrest and Headrest Sensor	70
Headrest Requirements	70
Jack connector on Cubo	72
How to place the Headrest Sensor on the wheelchair	72
Setting up the System	73
Setting up the Omni and the GyroSet™ Link	73
Programming the Omni	73
Setting up the IOM and the GyroSet™ Link	75
Setting up the Dynamic Controls Linx DLX-IN500 and the GyroSet™ Link	75
Setting up the Quantum Rehab Q-Logic 3 EX Enhanced Display or SCIM Module and the GyroSet™ Link	75
Pairing instructions	76
Setting up the Vigo	76
Pairing with your phone (optional: to receive calls and listen to auditory type entertainment)	76
GyroSet™ LINK CONFIGURATION (Available for authorized dealers only)	77

Personalize the driving experience	77
Setting the driving parameters in the OMNI for safe and smooth acceleration	78
How to wear and drive with the GyroSet™ Vigo	80
How to wear the Vigo	80
Turn on the System (for assistants/carers)	81
Driving and mousing with the GyroSet™ Vigo	82
Switch modes with the Vigo	82
Drive mode	82
Mouse mode	82
Switching between available functions	83
Resting	83
Two Dongle Support	83
Drive with your Vigo	84
Using the OMNI Menu	84
Other GyroSet™ Vigo Functions:	85
Answer an incoming call	85
End a call	85
Reject a call	85
Adjust the volume	85
Play/Pause	85
Power off	85
Battery charging & battery level	85
Music streaming	86
GyroSet™ Vigo Product Specifications	86
Appendix	86
GyroSet™ Vigo LED Indications:	87
GyroSet™ Dongle LED Status Feedback	87
Resetting GyroSet™ Dongle manually	88
GyroSet™ Link LED (GyroSet™ Logo) Indications:	89
GyroSet™ Link Audible feedback:	90
GyroSet™ Cubo system status feedback	91
Other important display messages and items:	92
Resetting GyroSet™ Cubo manually	93
SPECIAL SAFETY CHECKLIST	94
WARRANTY	96
Revision History	96

User Guide

R-Net Omni® and the R-Net logo is the property and registered trademark of PG Drives Technology. NOW technologies Ltd. is not associated with PG Drives Technology.

Quantum Q-Logic is the property and registered trademark of Quantum Rehab. NOW technologies Ltd. is not associated with Quantum Rehab.

Linx is the property and registered trademark of Dynamic Controls. NOW technologies Ltd. is not associated with Dynamic Controls.

Please review this user manual before using the GyroSet™ Vigo with GyroSet™ Cubo.

Information contained in this publication regarding device applications and the like is provided only for your convenience and may be superseded by updates. It is your responsibility to ensure that your application meets with your specifications. NOW TECHNOLOGIES MAKES NO REPRESENTATIONS OR WARRANTIES OF ANY KIND WHETHER EXPRESS OR IMPLIED, WRITTEN OR ORAL, STATUTORY OR OTHERWISE, RELATED TO THE INFORMATION, INCLUDING BUT NOT LIMITED TO ITS CONDITION, QUALITY, PERFORMANCE, MERCHANTABILITY OR FITNESS FOR PURPOSE. NOW technologies disclaims all liability arising from this information and its use. Use of NOW technologies devices in life support and/or safety applications is entirely at the buyer's risk, and the buyer agrees to defend, indemnify and hold harmless NOW technologies from any and all damages, claims, suits, or expenses resulting from such use. No licenses are conveyed, implicitly or otherwise, under any NOW technologies intellectual property rights.

The NOW technologies and GyroSet™ logo are registered trademarks of NOW technologies Ltd.

It is our intention to provide our valued customers with the best documentation possible to ensure the successful use of your NOW technologies products. To this end, we will continue to improve our publications to better suit your needs. Our publications will be refined and enhanced as new volumes and updates are introduced. If you have any questions or comments regarding this publication, please contact our Helpdesk via email at info@nowtech.hu. We welcome your feedback.

You can find detailed tutorial videos on setting up the system at
<https://www.nowtech.hu/tutorials/>

SYSTEM REQUIREMENTS

A *wheelchair* equipped with:

- **PGDT R-Net:**
 - **Omni** or
 - **Omni2** or
 - **IOM Input/Output Module**, or
- **Dynamic Controls:**
 - **Linx DLX-IN500**, or
- **Quantum Rehab:**
 - **Q-Logic 3 EX Enhanced Display** or **SCIM Module**

Requirements for the **GyroSet™ Drive** software that enables the personalization of the driving experience and **GyroSet™ Mouse** that allows customization of the mousing experience:

- Either a Mac computer with High Sierra operating system or later
- Or a personal computer with a Windows 8 or later operating system

STATEMENT OF THE INTENDED PURPOSE AND USERS

The device is intended to be used as a specialty controller input device attached to power wheelchair controller systems. Users of the device are power wheelchair users who have difficulty using standard wheelchair input devices.

Safety and Handling Instructions

BATTERIES

Don't attempt to replace any of the GyroSet™ System's batteries yourself – you may damage the battery, which could cause overheating, fire, and injury. The lithium-polymer battery in your GyroSet™ Vigo should be serviced or recycled by NOW technologies Ltd. or an authorized service provider and must be recycled or disposed of separately from household waste. Dispose of the batteries according to your local environmental laws and guidelines.

THE GyroSet™ VIGO USES A LITHIUM-POLYMER BATTERY

Keep it away from anything that can catch fire and make sure it cannot get hit by sharp objects.

For charging, only use the charging cord provided.

Avoid storing and using the GyroSet™ Vigo below -10 and above 50 degrees Celsius. Do not place the GyroSet™ Vigo in direct sunlight or keep it in hot vehicles.

Stop using the GyroSet™ Vigo if you notice these problems: odor, change in color, too much heat, change in shape, leaking, odd noises. If it is safe to do so, move the device away from anything that can catch fire.

MEDICAL DEVICE INTERFERENCE

GyroSet™ Link, GyroSet™ Vigo and the GyroSet™ Cubo contain components and radios that emit electromagnetic radiation. This electromagnetic radiation – although unlikely - may interfere with pacemakers, defibrillators, or other medical devices. Maintain a safe distance of separation between your medical device and the above mentioned GyroSet™ devices. Consult your physician and medical device manufacturer for information specific to your medical device. If you suspect any of your GyroSet™ devices are interfering with your pacemaker, defibrillator, or any other medical device, stop using the GyroSet™ system.

SPECIAL SAFETY WARNING

When driving with the GyroSet™ Drive system, do not forget to switch modes in order to be able to safely look around or control the actuator(s).

When driving with the GyroSet™ Drive system, make sure that the user is properly trained by a trained professional and have enough (a couple of weeks minimum) indoor experience driving the wheelchair before starting to drive outdoors in traffic.

Always make sure that the blink detection sensor is in a safe distance from your eye, cheek, or the corner of your mouth – 1-3 cm – and in a position that a sudden change in the position of the GyroSet™ Vigo won't hurt your eye.

Circumstances that can affect the operation of the GyroSet™ Vigo:

The GyroSet™ head drive offers unprecedented freedom of movement by using wireless radio communication. The operation can be disturbed in environments with above-average Bluetooth or Wifi device usage, this may result in a safety stop.

Please refer to our special safety checklist at the end of this document!

Getting Started

What's in the box

- GyroSet™ Link
- USB to micro-USB cable to charge the GyroSet™ Vigo
- GyroSet™ Dongle
- GyroSet™ Vigo with plastic “C” mounting ring
- The headband of GyroSet™ Vigo
- Special Micro-USB to Micro-USB cable to connect the GyroSet™ Link and the GyroSet™ Cubo
- GyroSet™ Cubo
- Headrest Sensor





GyroSet™ Vigo

What does the Vigo do?

The GyroSet™ Vigo is a headset that measures the head movements of the user in three dimensions and transfers signals to the GyroSet™ Cubo via Bluetooth to enable driving. It also supports other functions such as receiving phone calls and listening to music (not recommended while driving).

Important: Please make sure to pay attention to the “Battery Low” warning signals from the Vigo. Depending on usage the Vigo will shut down after approx. 10 minutes from the first warning. Please make sure to put the Vigo on a USB charger as soon as the “Battery Low” warning has been announced. It is advised that users take a USB power bank with them when going outdoors.

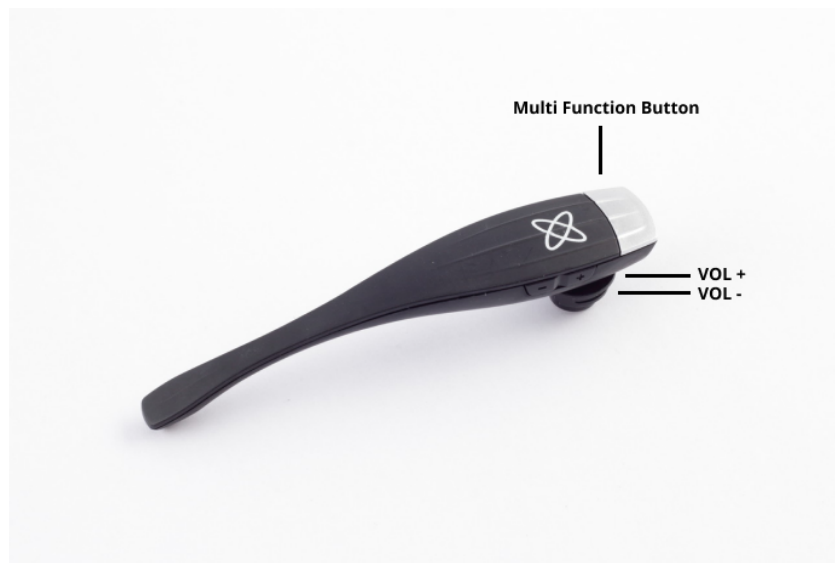



GyroSet™ Cubo

What does the Cubo do?

The Cubo provides visual feedback to the end-user via its display. It also receives the signals from the GyroSet™ Vigo, calculates the orientation of the user's head and transfers commands to the GyroSet™ Link.



GyroSet™ LINK

What does the LINK do?

The GyroSet™ Link translates the user's head movements into analog joystick signals that are interpreted by the wheelchair's controller system.

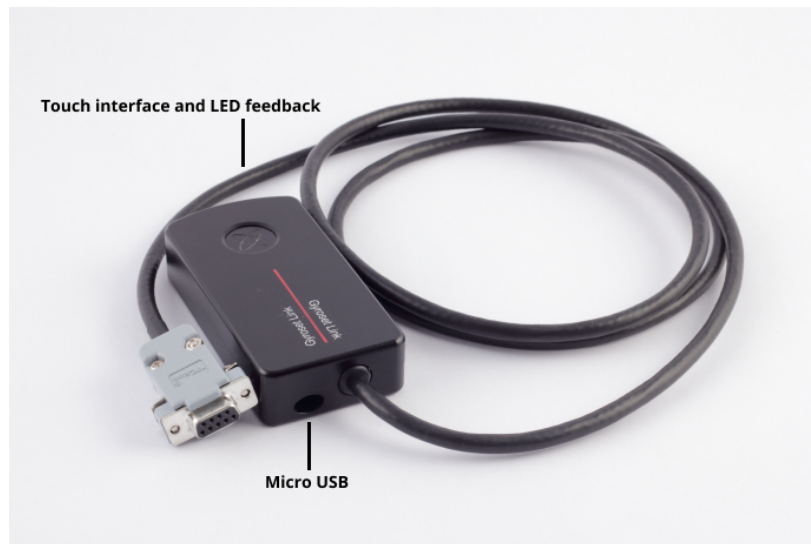

GyroSet™ Mouse Application

GyroSet™ Mouse is the desktop application that unlocks several extra features (like a virtual keyboard) for the GyroSet™ Vigo as a computer mouse. It also allows users to customize settings for the mouse mode, for the best user experience.

GyroSet™ Mouse is available to download from:

<https://nowtech.hu/downloads>

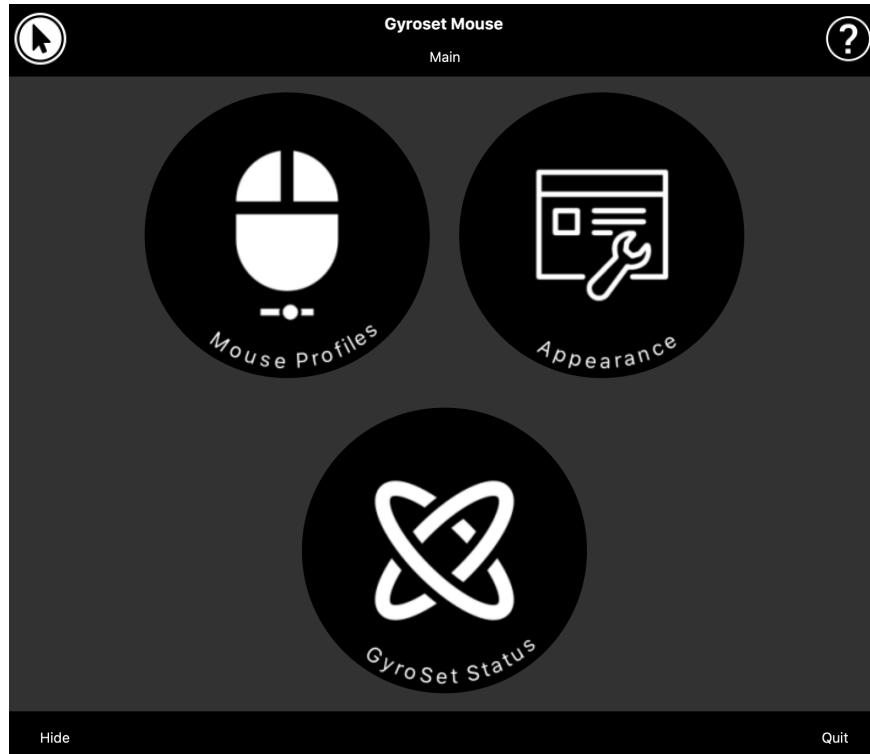

GyroSet™ Drive Application (Available for authorized dealers only)

GyroSet™ Drive is a desktop application that allows specialists to customize the Vigo's sensitivity settings for the best driving experience.

If you find your headset difficult to use, please make sure to contact your local distributor to have them adjust settings!

Assembly instructions

System connection diagram

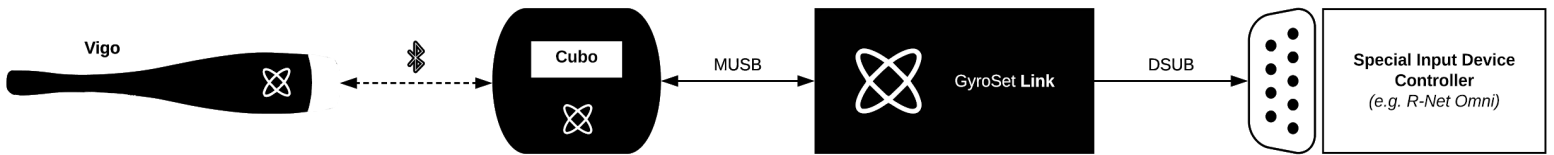

GyroSet™ Vigo assembly



To ensure the Vigo is securely attached into the headband, the open end of the C-ring should always point towards the end or the back of the Vigo (i.e. the "mouth" of the C should be perpendicular to the headband), otherwise, it can fall out of the headband.



Please make sure to check the C-ring's position every time you put the headset on the user, or adjust the Vigo's position in the headband!

GyroSet™ Link installation

GyroSet™ Link enables GyroSet™ Vigo users to use their GyroSet™ Vigo on a PGDT Omni or IOM or Quantum Q-Logic 3 EX Enhanced Display or SCIM Module or Dynamic Linx DLX-IN500 equipped wheelchair as a specialty input device (SID). The Omni is a universal specialty controls interface that accepts signals from many different types of SIDs and translates them into commands compatible with the PG Drives Technology R-Net control system.

Before proceeding please make sure that one of the compatible devices is already installed on the chair and working properly. For more information on how to set up the Omni please follow the instructions of R-Net OMNI TECHNICAL MANUAL SK78813/7. It is possible to set up a control system so that it is unsuitable for some users or even some vehicles. Although this guide contains recommended settings for Omni for all of the above reasons it is important that you contact PG Drives Technology if you have the slightest doubt or if you need any advice on programming the product.

GyroSet™ Link Mounting

The GyroSet™ Link enclosure has two M4 nuts at the back of the device that is designed specifically for mounting. As every vehicle and user is unique there is no general mounting bracket available.

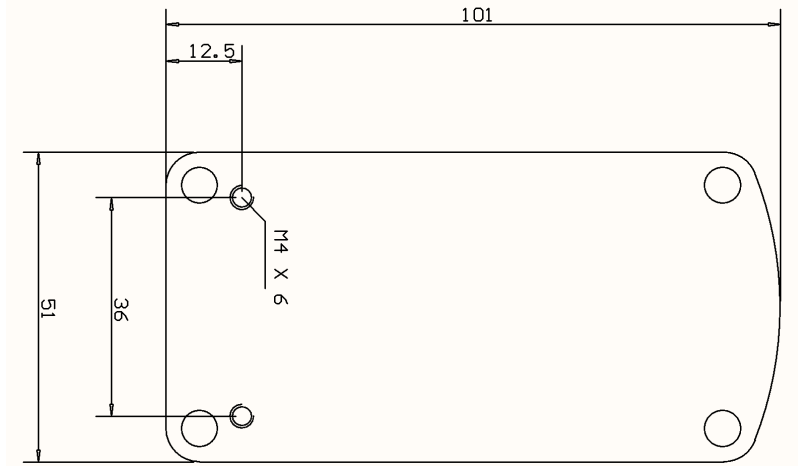

Please make sure that the physical mounting meets the following criteria:

- To take advantage of the IP54 protection of the casing, cables must face the ground to prevent rain getting into the connector:
- GyroSet™ Link's mode selection touch interface (touch button with the logo) must be accessible for the caretaker.
 - Devices that may produce high capacity charges, such as ionisators must be at a safe distance from the touch interface to avoid accidental activation.
- The audible feedback of the GyroSet™ Link is of high importance for the user, placement should avoid blocking of the speaker.



WARNING Protection against water according to IP54 is guaranteed only in case the Link has been installed in a vertical position.

GyroSet™ Link Wiring to PGDT

The **GyroSet™ Link** provides a proportional analog signal compatible with the PGDT Omni (and some other controller systems – see in System Requirements). The interface is a standard D-type connector, fitted with “detect link” and “fifth switch” functions. As there is no internal power source or auxiliary power input connector on the GyroSet™ Link the power for operation is provided by the Omni.

If the Omni is configured with the programmable parameter “Sleep 12V” to cut the power on SID connectors when turned off, GyroSet™ Link is going to be turned off as well. GyroSet™ Link doesn't require a permanent power supply. For power saving reasons “Sleep 12V” parameter is advised to be set in the R-Net system.

On the GyroSet™ Link there are two connector interfaces. One of which is an integrated cable with a D-type connector on it to control the Omni (referred to as Omni cable) and another oval-shaped interface to connect the GyroSet™ Glory cable (referred to as Data cable).



Omni Port-1 D-type connector



*The two interfaces of the GyroSet™ Link
(on the left oval-shaped data connector)*

The preferred SID port, if there is only one input device connected to the Omni, is Port 1 as shown in the picture below. In case of using a PGDT IOM there is only one INPUT port where the D-type connector can be connected:



Connecting the GyroSet™ Link to Omni

Connecting the GyroSet™ Link to IOM

Please make sure that the wiring meets the following criteria:

- The GyroSet™ Link must be properly connected to PGDT Omni or IOM or Quantum Q-Logic 3 via an Enhanced Display or a SCIM Module.
 - The GyroSet™ Link D-type connector connecting to the wheelchair controller must be secured with screws.
 - Cable to the wheelchair must be tied to the frame to avoid accidental tearing or crushing by the movement of actuators.
 - Cable placement has to be designed so that cables are protected during accidental crashes if the wheelchair hits an obstacle.
 - The analog connector should be connected to Omni Port-1 or IOM INPUT only.

In case the Omni's SID detect function is turned on and the D-type connector has become disconnected, a screen will appear on the Omni with error code 0905:



WARNING Always make sure that the chair is configured in a way that the chair's on/off switch is available to the user, according to the manufacturer's guidance.

GyroSet™ Cubo Mounting

The GyroSet™ Cubo enclosure has two M4 nuts at the back of the device that is designed specifically for mounting. As every vehicle and user is unique there is no general mounting bracket available.

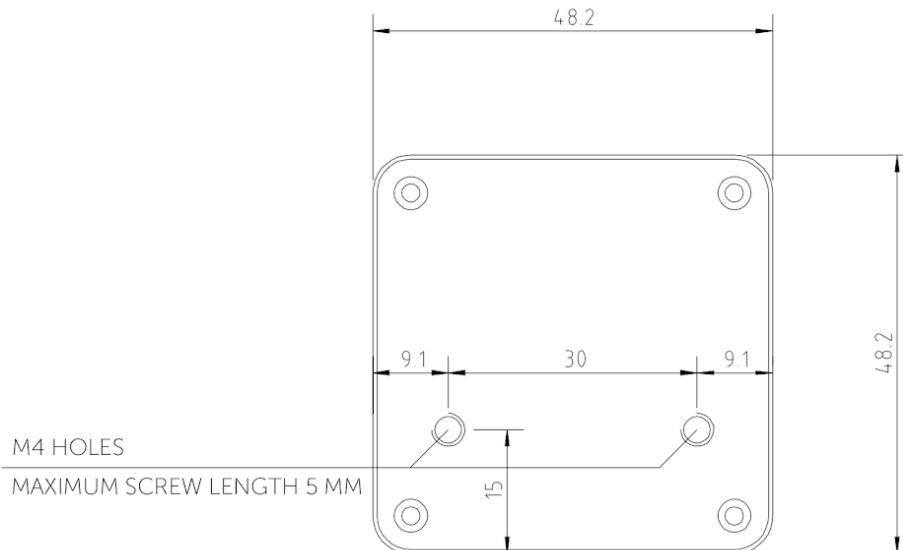

- ❑ Devices that may produce radio interference, such as Smartphones, Pagers, Bluetooth devices must be kept out of the way and placed at a distance from the GyroSet™ Cubo.
- ❑ GyroSet™ Cubo should be placed so that the display is visible for the user and the assistant/carer as well.

- ❑ To take advantage of the IP54 protection of the casing, cables must face the ground to prevent rain getting into the connector:
- ❑ We recommend placing the Cubo on the same side as the user wears the Vigo.
- ❑ Please make sure that the placement of the GyroSet™ Cubo allows for protection against mechanical damages (e.g. falling objects) for the display.

Connecting the GyroSet™ Cubo to the Link and to the Headrest Sensor



Headrest Sensor Connector Link Connector



Please make sure that the wiring meets the following criteria:

- The GyroSet™ Cubo must be properly connected to GyroSet™ Link and the Headrest Sensor.
 - The GyroSet™ Cubo Micro-USB and the headrest's cable must be tied to the frame of the wheelchair to avoid accidental tearing or crushing by the movement of actuators.
 - The GyroSet™ Cubo Micro-USB and the headrest's cable placement has to be designed so that cables are protected during accidental crashes if the wheelchair hits an obstacle.

Headrest and Headrest Sensor

For safety reasons we strongly recommend using the Headrest Sensor as it has been designed to fulfill both emergency stop and drive start functions while enabling the users to rest their head while not driving.

Headrest Requirements

Suitable headrests must have a fairly hard foam density and a large enough flat or almost flat surface space to accommodate the full size of the headrest sensor in its pouch. It can be mounted on the outside of the headrest or placed under the removable cover of the wheelchair headrest. The removable cover must be a tight fit around the headrest foam to ensure the sensor is snug and tight between the surfaces to stop it from moving and keep it secure.

An example of the ideal shape of the headrest:



Unsuitable headrests examples:

Very puffy and soft density foams that do not allow the sensor to operate at optimum performance.



Headrests that are too curved or with too small a surface to accommodate the size of the pouch or sensor alone.



Hard rubberized with deep curves and dips not allowing a flat enough surface for the sensor.



Jack connector on Cubo

Jack connector is the interface for connecting auxiliary buttons and sensors to the system. The route of the signal coming from the button can be redirected to be processed by either the Cubo itself or by the Link. By default, the signal is processed by the Cubo.

- The Link as the receiver is compatible strictly with sensors and buddy buttons manufactured by NOW technologies Ltd. - such as the Headrest Sensor.
- In case the Cubo is set to receive Jack signals any kind of NOW technologies or third party buddy button can be used.

How to place the Headrest Sensor on the wheelchair



Please make sure that the wiring meets the following criteria:

- The Headrest Sensor must be properly connected to GyroSet™ Cubo.
 - The Headrest Sensor's cable must be tied to the frame of the wheelchair to avoid accidental tearing or crushing by the movement of actuators.
 - The Headrest Sensor's cable placement has to be designed so that cables are protected during accidental crashes if the wheelchair hits an obstacle.
- The Headrest Sensor must be tied to the headrest by the reusable tie and strap in a way that it won't move during extended periods of usage.
- Please make sure that the position of the Headrest Sensor is easily reachable for the specific user during driving.

Setting up the System

Setting up the Omni and the GyroSet™ Link

Please find our tutorial videos on <https://www.nowtech.hu/tutorials/>

GyroSet™ Link and the GyroSet™ Cubo enable GyroSet™ Head Drive users to use their GyroSet™ Vigo on a PGDT Omni or IOM equipped wheelchair as a specialty input device (SID). The Omni is a universal specialty controls interface that accepts signals from many different types of SIDs and translates them into commands compatible with the PG Drives Technology R-Net control system.

Programming the Omni

For programming the Omni please follow the instructions provided by Penny and Giles Drive Technologies. There are three methods of programming the Omni. Details of the actual programmable parameters are given in the SK78813 Programming chapter. Ensure the R-Net Control System's Drive, Acceleration and Deceleration settings are at a comfortable and safe level prior to attempting to program the Omni to suit the user. Refer to the R-Net Technical Manual SK77981 or the On-Board Programming Manual SK78571 for details of how to program the R-Net Control System. Programming should only be conducted by professionals with in-depth knowledge of PG Drives Technology electronic control systems. Incorrect programming could result in an unsafe set-up. NOW technologies Ltd. accepts no liability for losses of any kind if these conditions are not met.

Omni			
Global			
Sip and Puff			
Scan Speed	1.0 s		
Sleep 12V	Off		
Profiled	Profile VMP	Ilona	No Tech
Ports			
SID	Port 1	Port 2	
SID	Proportional	Proportional	
Switches	Port 1	Port 2	
User Switch	Normally Open	Normally Closed	
Switch Detect	Off	On	
9-Way Detect	On	Off	
Switch Long	5.00 s	1.00 s	
Switch Medium	1.00 s	1.00 s	
Switch Debounce	50 ms	50 ms	
Double Click	0.3 s	0.3 s	
Controls	Port 1	Port 2	
User Control	Menu	Menu	
Return To	Drive	Drive	
Timeout to Menu	0 s	0 s	
Menu Navigation	Normal	Normal	
Menu Scan Rate	0.00 s	0.50 s	
Auto-repeat	Off	Off	
Fwd / Rev Auto Toggle	Off	Off	
Auto Toggle Time	2.00 s	2.00 s	
Actuator Selection	SID	SID	
Actuator Axes	Normal	Normal	
User Menu	Port 1	Port 2	
Beeps	Port 1	Port 2	
Training Mode			

Using the R-Net PC programmer to configure Omni, Port 1 SID has to be set to **proportional**. To use the Click sensor of the GyroSet™ Vigo to activate menu functions on the Omni, Port 1 User control has to be set to **Menu and Return To Drive**.

Input Output Module			
Input Module	Input 1	Input 2	Input 3
Input Type	Proportional	Proportional	Proportional
Output Module	Output 3	Output 4	Output 5

 **WARNING** The Omni can be put to sleep by selecting that option in the User Menu. To wake the Omni, the following SID sequence is required: Left, Right, Left, Right. Note, this waking method only works if the Omni has been put to sleep via the User Menu. For that to work the “Sleep 12V” parameter has to be turned off to allow the GyroSet™ Link to operate constantly. For safe operation of the chair NOW technologies does not recommend the

above-described scenario, instead please **install the Headrest Sensor** within the reach of the User that can act as an emergency stop as well. For more instructions, see the “Headrest and Headrest Sensor” section.

Please make sure that your R-Net configuration meets the following criteria:

- The correct SID port is configured as proportional.
- Sleep 12V parameter is set.
- User control is set.
- Drive, Acceleration and Deceleration settings are at a comfortable and safe level.

To avoid control problems when changing your seating position, we recommend modifying your setting in the Omni to allow control of the actuators only when the head is tilted either to the left or right side.

Setting up the IOM and the GyroSet™ Link

Setting up the IOM with the GyroSet™ Link should only be conducted by the distributor or a PGDT trained person.

Setting up the Dynamic Controls Linx DLX-IN500 and the GyroSet™ Link

Setting up the Dynamic Controls Linx DLX-IN500 with the GyroSet™ Link should only be conducted by the distributor or a Dynamic Controls trained person.

Setting up the Quantum Rehab Q-Logic 3 EX Enhanced Display or SCIM Module and the GyroSet™ Link

Setting up the Quantum Q-Logic 3 EX Enhanced Display or SCIM Module with the GyroSet™ Link should only be conducted by the distributor or a Q-Logic trained person.

Setting up the Vigo

The GyroSet™ Vigo was paired to your system at the factory.

Pairing to your phone (optional: to receive calls and listen to auditory type entertainment)



WARNING Using this function will drastically decrease the battery life of your Vigo from an average of 14 hours of run-time to 4-5 hours.

1. In the mobile phone Settings, turn on Bluetooth. (iOS and Android: Settings > Bluetooth > On)
2. To pair Vigo with your mobile phone, press and hold the Vigo Multifunction Button for 7 seconds, until you hear the word "Pairing". The Alert LED will flash alternating red and blue.
3. In your mobile phone Settings, search for new Bluetooth devices.
4. Select "Vigo".
5. Once successfully paired, the Alert LED will stop flashing, and you will hear "Connected" spoken from the Vigo earpiece.

GyroSet™ LINK CONFIGURATION (Available for authorized dealers only)

If you are a user and you need to adjust the headset's settings, please contact your local distributor!

If you're one of our authorized dealers, please contact us at nowtech.hu/contact to request access to the software and the GyroSet™ Drive manual!

Personalize the driving experience

1. Download and install the GyroSet™ Drive software from our website.
After the installation, the GyroSet™ Drive application should start running automatically (depending on the operating system version and the setup of your computer).
2. Insert the GyroSet™ Dongle into the computer's USB port.
3. Turn on the Omni. This will turn on your GyroSet™ Link and your GyroSet™ Cubo.
4. In GyroSet™ Drive, go to Drive Profile. For further information, click the Help (?) icon in the top right corner or download the GyroSet™ Drive Help document .

The GyroSet™ Link translates the user's head movements into analog joystick sweeps. For that to function correctly all GyroSet™ Link parameters must be set according to the individual user's needs. The configuration of the GyroSet™ Link can be achieved through the GyroSet™ Drive application - available only for distributors - that provides an interactive Help and settings Wizard, which you can find by clicking on the question mark icon in the top right corner of the

application on any page. The GyroSet™ Vigo can measure the tilting of the head in the four main directions, forward, backward, left and right.

Setting the driving parameters in the OMNI for safe and smooth acceleration

Speeds		HD
Maximum Forward Speed	80 %	
Minimum Forward Speed	10 %	
Maximum Reverse Speed	80 %	
Minimum Reverse Speed	10 %	
Maximum Turning Speed	80 %	
Minimum Turning Speed	10 %	
Maximum Forward Acceleration	15	
Minimum Forward Acceleration	15	
Maximum Forward Deceleration	20	
Minimum Forward Deceleration	15	
Maximum Reverse Acceleration	15	
Minimum Reverse Acceleration	10	
Maximum Reverse Deceleration	20	
Minimum Reverse Deceleration	15	
Maximum Turn Acceleration	25	
Minimum Turn Acceleration	25	
Maximum Turn Deceleration	30	
Minimum Turn Deceleration	30	
Power	100 %	
Torque	100 %	
Tremor Damping	50 %	
Fast Brake Rate	80	

1. Based on the factory default parameters, and according to the results of the test drive with a joystick, the assistant shall identify the highest speed values of the chair that enables the user to drive the chair safely:

1. Maximum Forward Speed
2. Maximum Reverse Speed
3. Maximum Turning Speed

2. It is recommended to set both acceleration and deceleration speeds to a relatively low value in order to avoid the swinging of the head. This could disturb the operation of the sensors.

- Maximum Forward Acceleration: 15-35
- Maximum Forward Deceleration: 20-40
- Maximum Reverse Acceleration: 15-35
- Maximum Reverse Deceleration: 20-40

- Maximum Turn Acceleration: 25-45
- Maximum Turn Deceleration: 30-40

3. The assistant shall validate the drivability of the chair by using the chair themselves. Twitch of the chair during acceleration, deceleration or especially driving forward can be caused by the swinging of the head. In this case, we recommend increasing the value of the Tremor Damping from zero step by step, until the chair is able to accelerate without twitches.

4. The end-user should validate the driving parameters by driving the chair with the GyroSet™ Vigo. The assistant shall modify the maximum speed values and the value of the Tremor Damping according to the user's needs.

5. It is recommended to create a copy of the final profile as a basis for other profiles. When for example the user needs a second profile for indoor driving, it is enough to use the copy of the outdoors profile and change only the maximum forward speed value and leaving the rest untouched.

The above-mentioned example values and ranges can greatly differ from user to user. It is recommended to always follow the above process when setting values to gain safe driving and smooth acceleration.

How to wear and drive with the GyrsoSet™ Vigo

How to wear the Vigo



1. Find a comfortable seating position for the user and adjust the headrest so that the Headrest Sensor is always in reach for the user (3-5 cm). Pushing the Headrest Sensor with the back of the head should always be an easy operation. Try to do that several times and adjust your chair/wheelchair's seating or headrest position if required.
2. Try the Vigo on the user's head. Adjust the headband in a way that it sits firmly on the top of the user's head, and they can wear it comfortably for hours. To ensure operational efficiency, adjust the Vigo on the head. The sensor should be placed approximately 3 cm from the movable parts of the user's face (corner of the eye, cheek, corner of the mouth, etc.)

Turn on the System (for assistants/carers)

1. To turn on the Vigo, press and hold the Multifunction Button on the Vigo for 5 seconds. The Alert LED will flash 3 times, Vigo will vibrate once, and you will hear “Power on” spoken from the Vigo earpiece if it’s close enough to your ears.
2. Put the Vigo safely on the head of the user: place it on the user’s head, adjust the click sensor’s flexible tube as described in this Manual. The sensor should be placed approximately 3 cm from the movable part of the user’s face (corner of the eye, cheek, corner of the mouth, etc.)
3. Turn on the Omni. This will turn on the GyroSet™ Link and the GyroSet™ Cubo
4. You will see the Bluetooth icon of the Cubo flashing and a No device text.



5. The Cubo will recognize the Vigo and the text “Link Drive” will appear.



6. Ask the user to push the Headrest Sensor, and when she starts hearing the sounds, push it again before the sounds are over. This will activate the Drive mode and Deactivate again to finish the calibration process. At the end of the process, the Link will be in an inactive state.

For other status displays, please see the GyroSet™ Cubo System Status Feedback section in the Appendix.



WARNING *If you ever experience that the chair is not exactly following your directions, stop driving and recalibrate the system. Follow the directions above and put the Vigo on a stable and flat surface after step 5 until the calibration icon changes to a checkmark (usually 5-10 seconds).*

Driving and mousing with the GyroSet™ Vigo

Switch modes with the Vigo

The default mode after the turn-on process is inactive drive mode.

Drive mode

To start driving, give the Headrest Sensor a short-press with the back of the head (0-1 seconds).

Emergency stop/Leave driving mode:

Push the Headrest Sensor with the back of the head with a fast (faster than reversing) movement. The chair will react immediately to the push of the sensor.

The chair stops also when the head leaves the range set in the GyroSet™ Drive application and also when the user is making fast, seizure-like movements.

Enter the Omni menu:

When the driving mode is inactive, use a face-wink gesture to enter the menu of the Omni.

To be able to navigate in the menu, the head drive needs to be in active mode, please use the Headrest Sensor to activate navigation in the menu.



WARNING Please do not leave the Omni menu by the Exit option in the menu as this will cause you immediately driving the chair. Instead, deactivate the menu navigation first by using the Headrest Sensor and then switch to drive mode with a face-wink to continue driving.

Mouse mode

To use this function, a connected set of GyroSet™ Dongle and GyroSet™ Vigo is sufficient.

If a GyroSet™ Cubo is present in the network, the user can switch between 'drive mode' and 'mouse mode' by long-pressing the Headrest Sensor, as described below.

Plug the GyroSet™ Dongle in the computer's USB port.

The color of the LED will indicate whether the Dongle is communicating with GyroSet™ Cubo or Vigo.

In a network where a Cubo is present, mousing can be initiated by short-pressing the Headrest Sensor.

In case of a GyroSet™ Dongle and GyroSet™ Vigo only connection, you can start mousing by pressing the Vigo's Multi-Function button.

In this setup we advise users to disable the headset button in their phone settings or disconnect their smartphone from GyroSet™ Vigo, otherwise the Multi Function button will start mousing on the computer and start playing music (or answer calls) on your phone at the same time.

The mousing experience can be greatly enhanced by using the **GyroSet™ Mouse** application, which allows the user to adjust and fine-tune how the cursor reacts to head movements. Its toolbar unlocks other mouse functionalities, like the right-click and the middle-click, provides shortcuts for modifier keys (Ctrl/Cmd, Alt/Option, Shift) and the most used editing functionalities for easy access.

During mousing a face-wink is equivalent with the click of a mouse.

Details on how to use the software are included in its Help section (question mark in the top right corner).

For a detailed explanation of the GyroSet™ Dongle's LED colors, please see the GyroSet™ Dongle LED Status Feedback section in the Appendix.

Switching between available functions

If the user has a system of at least the following connected devices: GyroSet™ Link, GyroSet™ Cubo, GyroSet™ Vigo and GyroSet™ Dongle (i.e. the potential to use 'drive mode' or 'mouse mode'), then they can switch between the modes these devices provide (in this case driving and mousing) by long-pressing (1-5 seconds) the Headrest Sensor.

The GyroSet™ Cubo's screen will show the current mode (e.g.: LINK drive, MOUSE).

Resting

Tap the Headrest Sensor quickly with the back of the head with a fast movement and hold your head on it for over 5 seconds. GyroSet™ Cubo's screen will flash and stay in the current mode. That will enable you to rest your head without the risk of accidentally initiating driving or mousing.

Drive with your Vigo

1. Imagine that your head is like a regular joystick.
2. Tilt your head (make sure not to turn as it has no effect) to the direction you wish to go. The tilt amount is proportional to the speed of the wheelchair's movement. Make slow, fluid and small movements with your head to avoid activating the emergency stop.
3. To come to a halt, move your head into the neutral position (into the dead-zone)
4. To stop driving press the Headrest Sensor.

For each drive session, a new neutral position can be selected, this helps in case the user changed their posture.

Using the OMNI Menu

1. To avoid control problems when changing your seating position, we recommend modifying your setting in the OMNI to control the actuators only with head side tilts.
2. When the chair is not moving the GyroSet™ Vigo's click sensor (face wink) can be used to enter into the Omni Menu.
3. Activate the head drive - by tapping firmly the Headrest Sensor - to navigate the menu.
4. Your head will act as a joystick to help you go through all the available preferences.
5. Select menu items with tilting your head right as with a joystick, but make sure to return to the neutral position
6. Use the face wink gesture again to deactivate the Omni menu navigation.

Other GyroSet™ Vigo Functions:

Answer and incoming call

Short-press the Multi-Function Button to answer the incoming call.

End a call

Short-press the Multi-Function Button to end the current call.

Reject a call

Long-press the Multi-Function Button for 2 seconds to reject the incoming call.

Adjust the volume

Press "VOL+" to increase volume. You will hear "beep" from the GyroSet™ Vigo earpiece.
Press "VOL-" to decrease volume. You will hear "beep" from the GyroSet™ Vigo earpiece.

Play/Pause

Short-press the Multi-Function Button to play/pause the music.

Power off

To power off GyroSet™ Vigo, press and hold the Multi-Function Button for 5 seconds. The Alert LED will flash blue 3 times, and you will hear “Power off” spoken from the GyroSet™ Vigo earpiece.

Battery charging & battery level

Charging: Use the included USB cable for charging. The Alert LED will turn red while charging.

Charging time: 2 hours. When fully charged, the Alert LED will turn off.

Low battery: You will hear “Battery Low” spoken from the GyroSet™ Vigo earpiece.

Important: Please make sure to pay attention to the “Battery Low” warning signals from the Vigo. Depending on usage the Vigo will shut down after approx. 10 minutes from the first warning. Please make sure to put the Vigo on a USB charger as soon as the “Battery Low” warning has been announced. It is advised that users take a USB power bank with them when going outdoors.

Music streaming

Streaming audio is initiated and controlled by your mobile phone.

When a call rings, any streaming audio will automatically pause, to enable you to answer the call. When the call has ended, the streaming audio will resume.

Play/Pause: Click the Multi-Function Button once.

Previous song: Long-press “Vol+” for 2 seconds.

Next song: Long-press “VOL-” for 2 seconds.

GyroSet™ Vigo Product Specifications

1. Bluetooth operating range: Up to 10 meters (30 feet)
2. Talk time: 10 hours (only when used as a headset, not as Head Drive)
3. Audio playtime: 10 hours (only when used as a headset, not as Head Drive)
4. Standby time: 10 days
5. Charging time: 2 hours
6. Bluetooth version: 4.0
7. Bluetooth profile: Support HFP, HSP and A2DP
8. Charging: Micro-USB
9. Noise cancellation: Dual MEMS microphone technology



WARNING Do not press and hold the combination of the Power button and either of the Volume buttons. This will put the Vigo into DUT (service mode) which will render the Vigo unusable. In this state the Vigo cannot be turned off, you have to wait for the battery to deplete completely.

Appendix

GyroSet™ Vigo LED Indications:

Solid Red: Charging

No led while USB cable is attached to power: Fully charged

Flashing Red: Vigo's battery is low

Alternating Red and Cyan: Vigo is in pairing mode

Flashing Red, Green and Blue: Vigo has just been turned ON or OFF

LED flash blue once every 5 seconds: Vigo standby (without connecting to a phone)

LED flash cyan once every 7 seconds: Vigo working mode (connect to a phone) or playing music

LED double-flash cyan once every 3 seconds: incoming call, answer a call or dial-out

GyroSet™ Dongle LED Status Feedback

In normal mode:

Blinking blue light: Dongle is *not* connected to Vigo or Cubo

Continuous blue light: Dongle is connected to Vigo or Cubo

Continuous purple light: Dongle is connected and half-calibrated

Continuous cyan light: Dongle is connected and fully calibrated

During Firmware update:

White light: when firmware update starts in Bootloader mode

Yellow light: during firmware upload

Green light (for a moment before Dongle restarts): at successful update

Red light: when the firmware upload process fails

Resetting GyroSet™ Dongle manually

In case you need to reset your Dongle manually, please follow these steps:

1. Gently insert a pin (e.g.:straightened paper clip) into the small hole found on the opposite end from the USB plug.

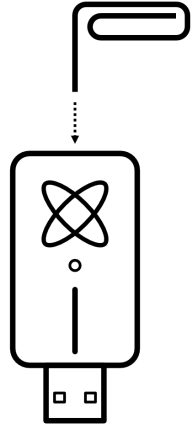

The pin has to be completely perpendicular to that face of the Dongle

2. Press the pin in until you feel the click of a small button
3. Press and hold this button for few seconds while you plug in the Dongle
4. The Dongle will come alive with a blinking blue light, meaning it's not paired to any device (it's been reset)

GyroSet™ Link LED (GyroSet™ Logo) Indications:









Colour	Light pattern	Status
None	No	The device is turned off or in sleep
White	Breathing: fade in – fade out	The device is turned on, but there is no headset
Blue	Breathing: fade in – fade out	Connection to the headset established through RADIO and IDLE
Blue	Blinking	Connection to the headset established through RADIO and ACTIVE
Green	Breathing: fade in – fade out	Connection to the headset established through CABLE and IDLE
Green	Blinking	Connection to the headset established through CABLE and ACTIVE
Orange	Breathing: fade in – fade out	GyroSet™ Link is in Service Mode
Red	1 short high sound signal	System halted due to an error. Driving stopped
Blue	Rapid blinking	Waiting for centering the head (RADIO connection)
Green	Rapid Blinking	Waiting for centering the head (CABLE connection)



GyroSet™ Link Audible feedback:

Please note that you can mute/unmute all Link sounds by a short touch on the GyroSet™ logo.

	Description	Meaning
. -	one short and low sound followed by a longer and higher sound	Linked turned on
. -	one very short, lower sound, followed by a longer and a little bit higher sound	Start driving
. _	one very short higher sound followed by a longer and a little bit lower sound	Stop driving
— — —	one very long sound repeating continuously	Reversing
.	one short, high sound	Fifth down
.	one short, high sound (a bit lower than fifth down)	Fifth up
.	one very short sound of average height	Set center/waiting
.	one very short beep sound	Mute

GyroSet™ Cubo system status feedback

	Description	Meaning
	<p>An arrow is running around the Bluetooth icon in a counterclockwise direction. A circle and a “no device” label are visible.</p>	<p>The system lost its binding with the GyroSet™ Vigo and is looking for the first GyroSet™ Vigo it is able to find.</p>
	<p>The Bluetooth icon is flashing. A circle and a “no device” label are visible.</p>	<p>The system is bound to, but doesn't have a connection with the GyroSet™ Vigo and is looking for it.</p>
	<p>The Bluetooth icon is highlighted. The clock hand in the circle is flipping. A “LINK Drive” label is visible.</p>	<p>The system is connected and is being calibrated. To enable the system to finish calibration, the GyroSet™ Vigo has to be in a stable, resting position.</p>
	<p>The Bluetooth icon is highlighted. A checkmark icon is highlighted. A “LINK Drive” label is visible.</p>	<p>The system is connected and ready for driving, but the drive mode is passive.</p>
	<p>The Bluetooth icon is highlighted. A checkmark icon is highlighted. The “LINK Drive” label is highlighted.</p>	<p>The system connected and is in an active drive mode.</p>
	<p>The entire screen lights up inverted.</p>	<p>The system is switching between modes in the channel map. (e.g. LINK Drive → MOUSE)</p>
	<p>The Bluetooth icon is highlighted. A checkmark icon is highlighted. A “MOUSE” label is visible.</p>	<p>The system is connected and ready for mousing, but the mouse mode is passive.</p>
	<p>The Bluetooth icon is highlighted. A checkmark icon is highlighted. The “MOUSE” label is highlighted.</p>	<p>The system connected and is in an active mouse mode.</p>

	<p>The Bluetooth icon is highlighted. A checkmark icon is highlighted. A "LINK Drive" label is blinking upon pressing the Headrest Sensor.</p>	<p>Driving cannot be initiated, GyroSet™ Link can't communicate with GyroSet™ Cubo.</p>
	<p>The Bluetooth icon is highlighted. A checkmark icon is highlighted. The "MOUSE" label is blinking upon pressing the Headrest Sensor.</p>	<p>Mousing cannot be initiated, GyroSet™ Vigo can't communicate with GyroSet™ Cubo.</p>

SPECIAL SAFETY CHECKLIST

Please make sure that the following criteria are met before trying to drive the wheelchair with the GyroSet™ Drive System:

- Understanding of the intended use of the GyroSet™ Cubo and the GyroSet™ Vigo by getting familiar with this User Manual.
- The adjustment of the headrest: The user must be able to reach the Headrest Sensor at any time to be able to activate it.
- The intended direction of movement must be set by using GyroSet™ Drive.
- The user's head movement range must be set by using GyroSet™ Drive.
- Out of operation range for the faint detection threshold must be set using GyroSet™ Drive.
- Tremor filter must be set using GyroSet™ Drive.
- Click sensor functions and parameters must be set using GyroSet™ Drive.
- Click sensor long-press maximal timeout must be set using GyroSet™ Drive.
- Centre mode and parameters must be set using GyroSet™ Drive:
 - Please make sure to check if the center mode is set to "Countdown" in GyroSet™ Drive. If yes, the "Timeout" has to be set.
- The maximum speed, acceleration, deceleration of the head drive profile of the wheelchair controller must be adjusted:
 - Settings of the controller must be administered specifically trained and authorized personnel.
 - Acceleration and deceleration settings of the wheelchair shall not cause inertia on the user's head that the user cannot compensate.
 - Maximum speed must always be in accordance with the local regulations.
- The service network must be used only for the time when changes are made to the personal drive profile.
- The user should avoid:
 - Environments with extreme radio interference when driving wirelessly as it may cause the wheelchair to stop if it receives no signals.
- The user shall be aware of the fact that the GyroSet™ Link must be selected by using the Headrest Sensor for control with the GyroSet™ Vigo.
- The user must be trained and know how to handle the center detection (jump to center).
 - In case the mode is set to countdown, the user's head shall be motionless in a neutral position after activating the drive function for a few seconds until the countdown stops.
 - In case the mode is set to automatic, the drive won't start until the head is put into a motionless state for less than a second.
- Be aware that the GyroSet™ Vigo acts as a joystick within the R-Net control system:
 - By programming the wheelchair controller, various functions can be tied to "fifth button" presses, in this case, the click sensor of the GyroSet™ Vigo.

- ❑ When the fifth button's long-press timeout is set to a smaller value on the R-Net than on the GyroSet™ Link the click sensor can turn the chair into sleep mode.
- ❑ In case the fifth button function is programmed so that the User can access the Omni menu, the GyroSet™ Vigo can be used to navigate within the menu using head gestures similar to the controller's joystick.
- ❑ In case the fifth button function is programmed so that the User can control actuators, the GyroSet™ Vigo can be used to move the actuators using head gestures similar to the controller's joystick.
- ❑ After the drive mode is initiated, a distinguishable audio feedback can be heard.
 - ❑ The chair will move according to the head movements and the profile settings of the GyroSet™ Link and the controller.
 - ❑ The chair will move until the function is deactivated or failure is detected. The chair stops immediately if a failure is detected, a cable is unplugged or wireless signal is lost.
 - ❑ The chair can be stopped while in drive mode by moving the user's head to the initial neutral position.
- ❑ In case the center of driving feels off compared to the initial center, the user shall stop and reinitiate drive, taking on a new center/neutral position.
- ❑ That depletion of the GyroSet™ Vigo's battery will cause the chair to stop.
 - ❑ The GyroSet™ Vigo's battery must be charged on a daily basis.
- ❑ If the GyroSet™ Vigo falls off, the chair stops.
- ❑ A sudden backward movement of the head inside the turning dead zone will force the system to execute an emergency brake of the chair.
- ❑ In case the user's head reaches the maximum of the range of operation the sweep of the head joystick is at maximum.
- ❑ If the user's head reaches the safety zone in any direction the chair will stop.
- ❑ If the user's head is in the range of the center dead zone the chair won't move or it will stop.



WARNING The microcontroller is protecting the firmware with built-in hardware fuses, any attempt on reading or modifying the content of the flash will fail. All user-related variables are encrypted, any attempt on gaining access to secure data will erase the chip content.

WARRANTY

NOW technologies Ltd. provides two year's full warranty on the products. This warranty covers any defects in materials or workmanship, with the exceptions stated below:

Faults resulting from the installation by an unqualified person. Any problem that is caused by abuse, misuse, extreme water damage, or extreme weather are not covered. Also, consequential and incidental damages are not recoverable under this warranty.

Revision History

Revision number	Changelog	Date of release
01	Original content	30 November 2019
02	Updated to pre-final release	10 May 2020
03	Minor updates	01 February 2021

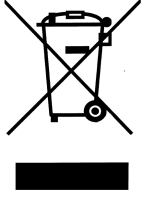

EUROPEAN UNION – DISPOSAL INFORMATION

The symbol above means that according to local laws and regulations your product and/ or its battery shall be disposed of separately from household waste. When this product reaches its end of life, take it

to a collection point designated by local authorities. The separate collection and recycling of your product and/or its battery at the time of disposal will help conserve natural resources and ensure that it is recycled in a manner that protects human health and the environment.

EU COMPLIANCE STATEMENT

NOW technologies Ltd. hereby declares that this wireless device is in compliance with the essential requirements and other relevant provisions of the R&TTE Directive and Radio Equipment Directive 2014/53/EU, as applicable. NOW technologies' EU representative is NOW technologies Ltd. 18. Reáltanoda street, Budapest, 1053 Hungary.

The GyroSet™ Drive components contain modules with the following FCC IDs:

GyroSet™ Link:

FCC ID: W70MRF24J40MDME

GyroSet™ Cubo:

FCC ID: 2AC7Z-ESPWROOM32D

GyroSet™ Vigo:

FCC ID: 2AFKV-VIGO

GyroSet™ Dongle:

FCC ID: SH6MDBT50Q

www.nowtech.hu



RoHS DECLARATION OF CONFORMITY

We hereby declare that our products are compliant to RoHS Directive 2011/65/EU of the European Parliament and the Council from 08/06/2011 on the restriction of the use of certain hazardous substances in electrical and electronic appliances.

NOW technologies Ltd. herewith declares that all of our products are manufactured in compliance with RoHS.

GyroSet™ HEAD DRIVE & MOUSE

USER MANUAL

Document identifier: NOW.Q.CE.M.EN-GS-0002-04

Revision: 04

Date of issue: 25 June 2021

©2021 NOW technologies Ltd. All rights reserved.

NOW technologies, the NOW technologies logo, and the GyroSet™ Glory and GyroSet™ Vigo names are trademarks of NOW technologies Ltd., registered in 18. Reáltanoda street, Budapest, 1053 Hungary.

European representative of the Manufacturer:

NOW technologies Ltd., 18. Reáltanoda street, Budapest, 1053 Hungary

www.nowtech.hu

You can find step-by-step tutorial videos at

www.nowtech.hu/tutorials/

User Guide

R-Net Omni® and the R-Net logo is the property and registered trademark of PG Drives Technology. NOW technologies Ltd. is not associated with PG Drives Technology.

Quantum Q-Logic is the property and registered trademark of Quantum Rehab. NOW technologies Ltd. is not associated with Quantum Rehab.

Linx is the property and registered trademark of Dynamic Controls. NOW technologies Ltd. is not associated with Dynamic Controls.

It is expressly advised to review this user manual before using the GyroSet™ Vigo with GyroSet™ Cubo.

Information contained in this publication regarding device applications and the like is provided only for your convenience and may be superseded by updates. It is your responsibility to ensure that your application meets with your specifications. NOW TECHNOLOGIES MAKES NO REPRESENTATIONS OR WARRANTIES OF ANY KIND WHETHER EXPRESS OR IMPLIED, WRITTEN OR ORAL, STATUTORY OR OTHERWISE, RELATED TO THE INFORMATION, INCLUDING BUT NOT LIMITED TO ITS CONDITION, QUALITY, PERFORMANCE, MERCHANTABILITY OR FITNESS FOR PURPOSE. NOW technologies disclaims all liability arising from this information and its use. Use of NOW technologies devices in life support and/or safety applications is entirely at the buyer's risk, and the buyer agrees to defend, indemnify and hold harmless NOW technologies from any and all damages, claims, suits, or expenses resulting from such use. No licenses are conveyed, implicitly or otherwise, under any NOW technologies intellectual property rights.

The NOW technologies and GyroSet™ logo are registered trademarks of NOW technologies Ltd.

It is our intention to provide our valued customers with the best documentation possible to ensure the successful use of your NOW technologies products. To this end, we will continue to improve our publications to better suit your needs. Our publications will be refined and enhanced as new volumes and updates are introduced. If you have any questions or comments regarding this publication, please contact our Helpdesk via email at info@nowtech.hu. We welcome your feedback.

You can find detailed tutorial videos on setting up the system at
<https://www.nowtech.hu/tutorials/>

SYSTEM REQUIREMENTS

A *wheelchair* equipped with:

- **PGDT R-Net:**
 - **Omni** or
 - **Omni2** or
 - **IOM Input/Output Module**, or
- **Dynamic Controls:**
 - **Linx DLX-IN500**, or
- **Quantum Rehab:**
 - **Q-Logic 3 EX Enhanced Display or SCIM Module**

Requirements for the **GyroSet™ Drive** software that enables the personalization of the driving experience and **GyroSet™ Mouse** software that allows customization of the mousing experience:

- Either a Mac computer with Catalina operating system or later
- Or a personal computer with a Windows 10 operating system or later

STATEMENT OF THE INTENDED PURPOSE AND USERS

The device is intended to be used as a specialty controller input device attached to power wheelchair controller systems. Users of the device are power wheelchair users who have difficulty using standard wheelchair input devices.

Safety and Handling Instructions

BATTERIES

Don't attempt to replace any of the GyroSet™ System's batteries yourself – you may damage the battery, which could cause overheating, fire, and injury. The lithium-polymer battery in your GyroSet™ Vigo should be serviced or recycled by NOW technologies Ltd. or an authorized service provider and must be recycled or disposed of separately from household waste. Dispose of the batteries according to your local environmental laws and guidelines.

THE GyroSet™ VIGO USES A LITHIUM-POLYMER BATTERY

Keep it away from anything that can catch fire and make sure it cannot get hit by sharp objects.

For charging, only use the charging cord provided.

Avoid storing and using the GyroSet™ Vigo below -10 and above 50 degrees Celsius. Do not place the GyroSet™ Vigo in direct sunlight or keep it in hot vehicles.

Stop using the GyroSet™ Vigo if you notice these problems: odor, change in color, too much heat, change in shape, leaking, odd noises. If it is safe to do so, move the device away from anything that can catch fire.

MEDICAL DEVICE INTERFERENCE

GyroSet™ Link, GyroSet™ Vigo and the GyroSet™ Cubo contain components and radios that emit electromagnetic radiation. This electromagnetic radiation – although unlikely - may interfere with pacemakers, defibrillators, or other medical devices. Maintain a safe distance of separation between your medical device and the above mentioned GyroSet™ devices. Consult your physician and medical device manufacturer for information specific to your medical device. If you suspect any of your GyroSet™ devices are interfering with your pacemaker, defibrillator, or any other medical device, stop using the GyroSet™ system.

SPECIAL SAFETY WARNING

When driving with the GyroSet™ Drive system, do not forget to switch modes in order to be able to safely look around or control the actuator(s).

When driving with the GyroSet™ Drive system, make sure that the user is properly trained by a trained professional and have enough (a couple of weeks minimum) indoor experience driving the wheelchair before starting to drive outdoors in traffic.

Always make sure that the blink detection sensor is at a safe distance from your eye, cheek, or the corner of your mouth – 1-3 cm – and in a position that a sudden change in the position of the GyroSet™ Vigo won't hurt your eye.

Circumstances that can affect the operation of the GyroSet™ Vigo:

The GyroSet™ head drive offers unprecedented freedom of movement by using wireless radio communication. The operation can be disturbed in environments with above-average Bluetooth or Wifi device usage, this may result in a safety stop.

Please refer to our special safety checklist at the end of this document!

Getting Started

What's in the box

- GyroSet™ Link
- USB to micro-USB cable to charge the GyroSet™ Vigo
- GyroSet™ Dongle
- GyroSet™ Vigo with plastic “C” mounting ring
- The headband of GyroSet™ Vigo
- Special Micro-USB to Micro-USB cable to connect the GyroSet™ Link and the GyroSet™ Cubo
- GyroSet™ Cubo
- Headrest Sensor





GyroSet™ Vigo

What does the Vigo do?

The GyroSet™ Vigo is a headset that measures the head movements of the user in three dimensions and transfers signals to the GyroSet™ Cubo via Bluetooth to enable driving. It also supports other functions such as receiving phone calls and listening to music (not recommended while driving).

Important: Please make sure to pay attention to the “Battery Low” warning signals from the Vigo. Depending on usage the Vigo will shut down after approx. 10 minutes from the first warning. Please make sure to put the Vigo on a USB charger as soon as the “Battery Low” warning has been announced. It is advised that users take a USB power bank with them when going outdoors.

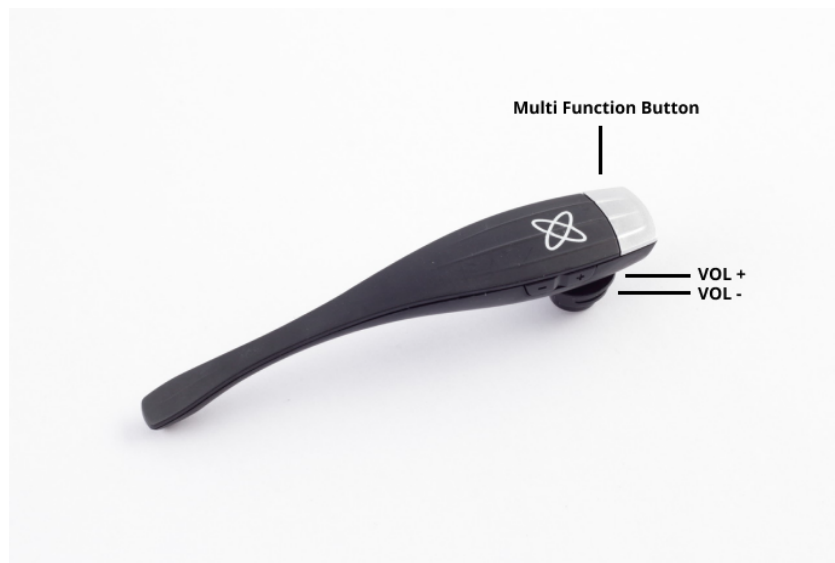



GyroSet™ Cubo

What does the Cubo do?

The Cubo provides visual feedback to the end-user via its display. It also receives the signals from the GyroSet™ Vigo, calculates the orientation of the user's head and transfers commands to the GyroSet™ Link.



GyroSet™ LINK

What does the LINK do?

The GyroSet™ Link translates the user's head movements into analog joystick signals that are interpreted by the wheelchair's controller system.

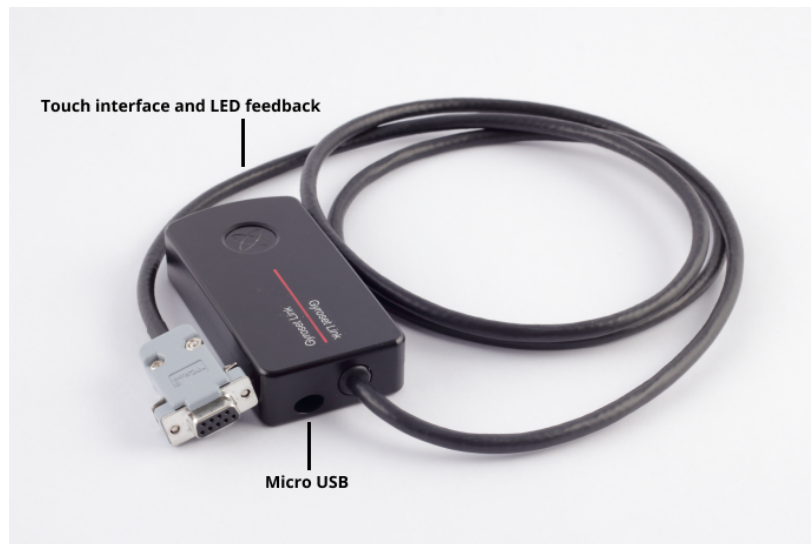

GyroSet™ Mouse Desktop Application

GyroSet™ Mouse is the desktop application that unlocks several extra features (like a virtual keyboard) for the GyroSet™ Vigo as a computer mouse. It also allows users to customize settings for the mouse mode, for the best user experience.

GyroSet™ Mouse is available to download from:

<https://nowtech.hu/downloads>

Important:

When using a MAC computer, please make sure to follow these steps:

- 1. Open Finder*
- 2. Locate the install file(.pkg) on your computer*
- 3. Right click on the file name*
- 4. Choose 'Open'*
- 5. And click 'Open' again in the pop-up window. This will enable the installation of the application.*

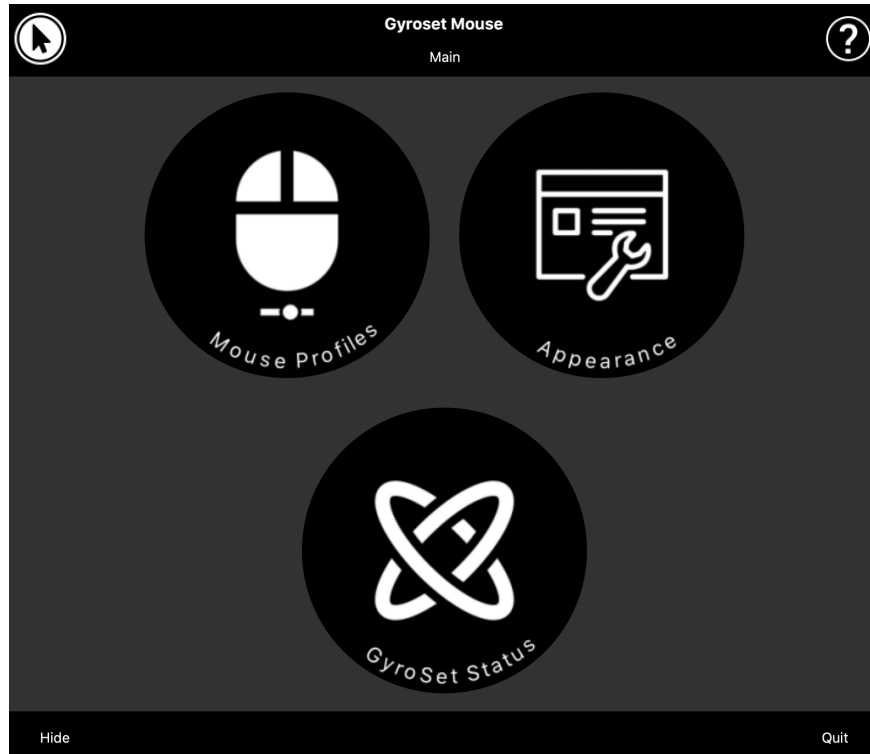

GyroSet™ Drive Desktop Application (Available for authorized dealers only)

GyroSet™ Drive is a desktop application that allows specialists to customize the Vigo's sensitivity settings for the best driving experience.

If you find your headset difficult to use, please make sure to contact your local distributor to have them adjust settings!

Important:

When using a MAC computer, please make sure to follow these steps:

- 1. Open Finder*
- 2. Locate the install file(.pkg) on your computer*
- 3. Right click on the file name*
- 4. Choose 'Open'*
- 5. And click 'Open' again in the pop-up window. This will enable the installation of the application.*

GyroSet™ Toolbox Mobile Application

GyroSet™ Toolbox is a mobile application that helps users to manage their Head Drive & Mouse Networks, to add and/or remove new GyroSet™ devices, and to keep their devices up to date with the latest firmware.

GyroSet™ Toolbox is available on the App Store or Google Play



Important:

- *We advise you to use GyroSet™ Toolbox with only one phone at a time. Its safe usage on multiple phones is not yet fully supported.*
- *If at any time during the Network setup process your phone requests pairing with GyroSet™ Dongle, make sure GyroSet™ Mouse (or GyroSet™ Drive) is running on the computer the Dongle is plugged into. This is to provide the Dongle with a platform through which it can communicate with your phone.*
- *If GyroSet™ Mouse (or GyroSet™ Drive) is not running on your computer, no Pairing pop-up window will appear in which you can input the pairing code provided by your phone and the Network cannot be set up. Moreover, Cubo may get stuck in this state of offering to pair with the Dongle and no other device can connect to it, until this is resolved.*
- *The same applies to pairing your GyroSet™ Dongle and GyroSet™ Cubo. If GyroSet™ Mouse (or GyroSet™ Drive) is not running on your computer, no Pairing pop-up window will appear in which you can input the 6 digit pairing code/passkey provided by GyroSet™ Cubo and the Network cannot be set up.*

Assembly instructions

System connection diagram

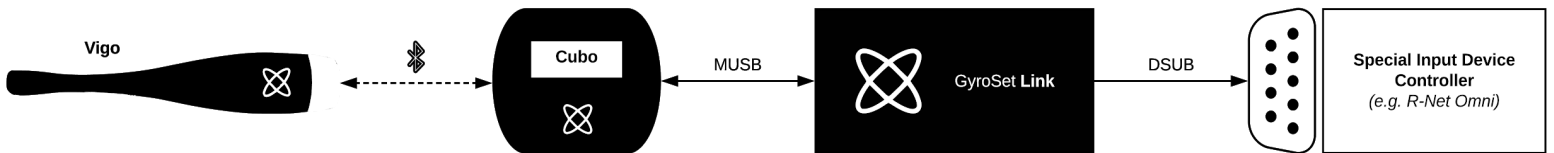

GyroSet™ Vigo assembly



To ensure the Vigo is securely attached into the headband, the open end of the C-ring should always point towards the end or the back of the Vigo (i.e. the "mouth" of the C should be perpendicular to the headband), otherwise, it can fall out of the headband.

Important: For safety reasons, make sure to charge the Vigo with the provided USB charging cable before the first use.



Make sure to check the C-ring's position every time you put the headset on the user, or adjust the Vigo's position in the headband !



***WARNING Please do not remove the C-ring from the Vigo!
Removing the C-ring may damage the device.***

GyroSet™ Link installation

GyroSet™ Link enables GyroSet™ Vigo users to use their GyroSet™ Vigo on a PGDT Omni or IOM or Quantum Q-Logic 3 EX Enhanced Display or SCIM Module or Dynamic Linx DLX-IN500 equipped wheelchair as a specialty input device (SID). The Omni is a universal specialty controls interface that accepts signals from many different types of SIDs and translates them into commands compatible with the PG Drives Technology R-Net control system.

Before proceeding please make sure that one of the compatible devices is already installed on the chair and working properly. For more information on how to set up the Omni please follow the instructions of R-Net OMNI TECHNICAL MANUAL SK78813/7. It is possible to set up a control system so that it is unsuitable for some users or even some vehicles. Although this guide contains recommended settings for Omni for all of the above reasons it is important that you contact PG Drives Technology if you have the slightest doubt or if you need any advice on programming the product.

GyroSet™ Link Mounting

The GyroSet™ Link enclosure has two M4 nuts at the back of the device that is designed specifically for mounting. As every vehicle and user is unique there is no general mounting bracket available.

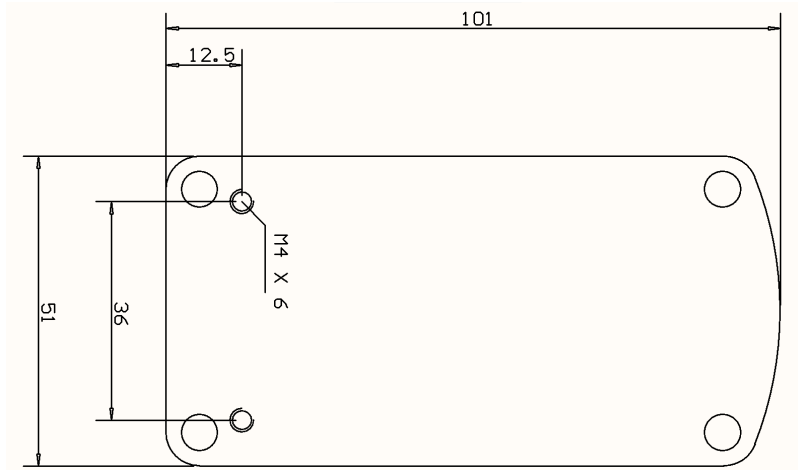

Please make sure that the physical mounting meets the following criteria:

- To take advantage of the IP54 protection of the casing, cables must face the ground to prevent rain getting into the connector.
- GyroSet™ Link's mode selection touch interface (touch button with the logo) must be accessible for the caretaker.
 - Devices that may produce high capacity charges, such as ionisators must be at a safe distance from the touch interface to avoid accidental activation.
- The audible feedback of the GyroSet™ Link is of high importance for the user, placement should avoid blocking of the speaker.
- Please don't exceed the minimum working temperature of -20°C and the maximum of 50°C of the GyroSet™ Link



WARNING Protection against water according to IP54 is guaranteed only in case the Link has been installed in a vertical position.

GyroSet™ Link Wiring to PGDT

The **GyroSet™ Link** provides a proportional analog signal compatible with the PGDT Omni (and some other controller systems – see in System Requirements). The interface is a standard D-type connector, fitted with “detect link” and “fifth switch” functions. As there is no internal power source or auxiliary power input connector on the GyroSet™ Link the power for operation is provided by the Omni.

If the Omni is configured with the programmable parameter “Sleep 12V” to cut the power on SID connectors when turned off, GyroSet™ Link is going to be turned off as well. GyroSet™ Link doesn’t require a permanent power supply. For power saving reasons “Sleep 12V” parameter is advised to be set in the R-Net system.

On the GyroSet™ Link there are two connector interfaces. One of which is an integrated cable with a D-type connector on it to control the Omni (referred to as Omni cable) and another oval-shaped interface to connect the GyroSet™ Glory cable (referred to as Data cable).



Omni Port-1 D-type connector



*The two interfaces of the GyroSet™ Link
(on the left oval-shaped data connector)*

The preferred SID port, if there is only one input device connected to the Omni, is Port 1 as shown in the picture below. In case of using a PGDT IOM there is only one INPUT port where the D-type connector can be connected:



Connecting the GyroSet™ Link to Omni

Connecting the GyroSet™ Link to IOM

Please make sure that the wiring meets the following criteria:

- The GyroSet™ Link must be properly connected to PGDT Omni or IOM or Quantum Q-Logic 3 via an Enhanced Display or a SCIM Module.
 - The GyroSet™ Link D-type connector connecting to the wheelchair controller must be secured with screws.
 - Cable to the wheelchair must be tied to the frame to avoid accidental tearing or crushing by the movement of actuators.
 - Cable placement has to be designed so that cables are protected during accidental crashes if the wheelchair hits an obstacle.
 - The analog connector should be connected to Omni Port-1 or IOM INPUT only.

In case the Omni's SID detect function is turned on and the D-type connector has become disconnected, a screen will appear on the Omni with error code 0905:



WARNING Always make sure that the chair is configured in a way that the chair's on/off switch is available to the user, according to the manufacturer's guidance.

GyroSet™ Cubo Mounting

The GyroSet™ Cubo enclosure has two M4 nuts at the back of the device that is designed specifically for mounting. As every vehicle and user is unique there is no general mounting bracket available.

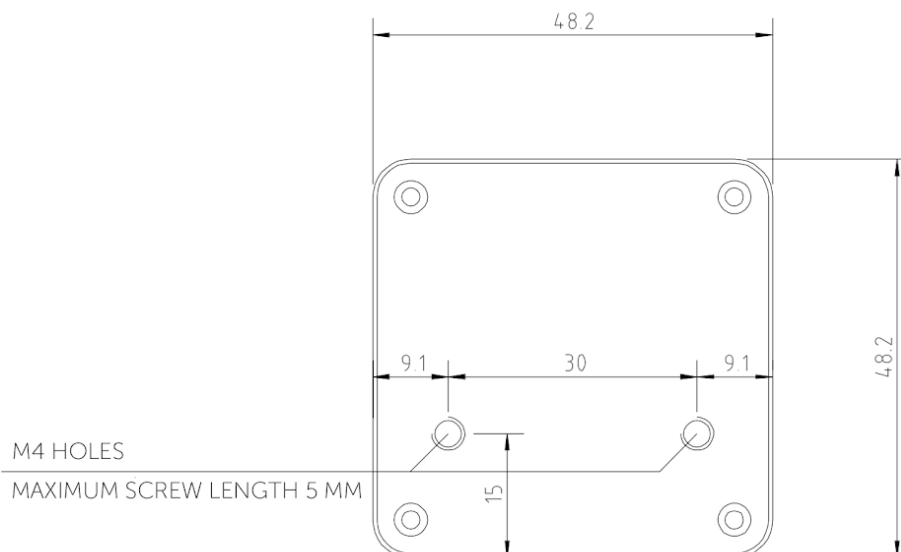

- ❑ Devices that may produce radio interference, such as Smartphones, Pagers, Bluetooth devices must be kept out of the way and placed at a distance from the GyroSet™ Cubo.
- ❑ GyroSet™ Cubo should be placed so that the display is visible for the user and the assistant/carer as well.

- ❑ To take advantage of the IP54 protection of the casing, cables must face the ground to prevent rain getting into the connector.
- ❑ We recommend placing the Cubo on the same side on which the user wears the Vigo.
- ❑ Please make sure that the placement of the GyroSet™ Cubo allows for protection against mechanical damages (e.g. falling objects) for the display.

Connecting the GyroSet™ Cubo to the Link and to the Headrest Sensor



Headrest Sensor Connector Link Connector



Please make sure that the wiring meets the following criteria:

- The GyroSet™ Cubo must be properly connected to GyroSet™ Link and the Headrest Sensor.
 - The GyroSet™ Cubo Micro-USB and the headrest's cable must be tied to the frame of the wheelchair to avoid accidental tearing or crushing by the movement of actuators.
 - The GyroSet™ Cubo Micro-USB and the headrest's cable placement has to be designed so that cables are protected during accidental crashes if the wheelchair hits an obstacle.

Headrest and Headrest Sensor

For safety reasons we strongly recommend using the Headrest Sensor as it has been designed to fulfill both emergency stop and drive start functions while enabling the users to rest their head while not driving.

Headrest Requirements

Suitable headrests must have a fairly hard foam density and a large enough flat or almost flat surface space to accommodate the full size of the headrest sensor in its pouch. It can be mounted on the outside of the headrest placed or under the removable cover of the wheelchair headrest. The removable cover must be a tight fit around the headrest foam to ensure the sensor is snug and tight between the surfaces to stop it from moving and keep it secure.

An example of the ideal shape of the headrest:



Unsuitable headrests examples:

Very puffy and soft density foams that do not allow the sensor to operate at optimum performance.



Headrests that are too curved or with too small a surface to accommodate the size of the pouch or sensor alone.



Hard rubberized with deep curves and dips not allowing a flat enough surface for the sensor.



Jack connector on Cubo

Jack connector is the interface for connecting auxiliary buttons and sensors to the system. The route of the signal coming from the button can be redirected to be processed by either the Cubo itself or by the Link. By default, the signal is processed by Cubo.

- The Link as the receiver is compatible strictly with sensors and buddy buttons manufactured by NOW technologies Ltd. - such as the Headrest Sensor.
- In case the Cubo is set to receive Jack signals any kind of NOW technologies or third party buddy button can be used.

How to place the Headrest Sensor on the wheelchair



Please make sure that the wiring meets the following criteria:

- The Headrest Sensor must be properly connected to GyroSet™ Cubo.
 - The Headrest Sensor's cable must be tied to the frame of the wheelchair to avoid accidental tearing or crushing by the movement of actuators.
 - The Headrest Sensor's cable placement has to be designed so that cables are protected during accidental crashes if the wheelchair hits an obstacle.
- The Headrest Sensor must be tied to the headrest by the reusable tie and strap in a way that it won't move during extended periods of usage.
- Please make sure that the position of the Headrest Sensor is easily reachable for the specific user during driving.

Setting up the System

Setting up the Omni and the GyroSet™ Link

Please find our tutorial videos on <https://www.nowtech.hu/tutorials/>

GyroSet™ Link and the GyroSet™ Cubo enables GyroSet™ Vigo users to use their GyroSet™ Vigo on a PGDT Omni or IOM equipped wheelchair as a specialty input device (SID). The Omni is a universal specialty controls interface that accepts signals from many different types of SIDs and translates them into commands compatible with the PG Drives Technology R-Net control system.

Important: Please be aware, whilst controlling your chair via the Omni (and the GyroSet™ Head Drive system), you won't be able to use your regular Joystick!
If you would like to use the Joystick after all, just turn off the Omni and turn the system back on with the power button on the Joystick.

Programming the Omni

For programming the Omni please follow the instructions provided by Penny and Giles Drive Technologies. There are three methods of programming the Omni. Details of the actual programmable parameters are given in the SK78813 Programming chapter. Ensure the R-Net Control System's Drive, Acceleration and Deceleration settings are at a comfortable and safe level prior to attempting to program the Omni to suit the user.

Refer to the R-Net Technical Manual SK77981 or the On-Board Programming Manual SK78571 for details of how to program the R-Net Control System. Programming should only be conducted by professionals with in-depth knowledge of PG Drives Technology electronic control systems. Incorrect programming could result in an unsafe set-up. NOW technologies Ltd. accepts no liability for losses of any kind if these conditions are not met.

Omni			
Global			
Sip and Puff			
Scan Speed	1.0 s		
Sleep 12V	Off		
Profiled	Profile VMP	Ilona	No Tech
Ports			
SID	Port 1	Port 2	
SID	Proportional	Proportional	
Switches	Port 1	Port 2	
User Switch	Normally Open	Normally Closed	
Switch Detect	Off	On	
9-Way Detect	On	Off	
Switch Long	5.00 s	1.00 s	
Switch Medium	1.00 s	1.00 s	
Switch Debounce	50 ms	50 ms	
Double Click	0.3 s	0.3 s	
Controls	Port 1	Port 2	
User Control	Menu	Menu	
Return To	Drive	Drive	
Timeout to Menu	0 s	0 s	
Menu Navigation	Normal	Normal	
Menu Scan Rate	0.00 s	0.50 s	
Auto-repeat	Off	Off	
Fwd / Rev Auto Toggle	Off	Off	
Auto Toggle Time	2.00 s	2.00 s	
Actuator Selection	SID	SID	
Actuator Axes	Normal	Normal	
User Menu	Port 1	Port 2	
Beeps	Port 1	Port 2	
Training Mode			

Using the R-Net PC programmer to configure Omni, Port 1 SID has to be set to **proportional**. To use the Click sensor of the GyroSet™ Vigo to activate menu functions on the Omni, Port 1 User control has to be set to **Menu and Return To Drive**.

Input Output Module			
Input Module	Input 1	Input 2	Input 3
Input Type	Proportional	Proportional	Proportional
Output Module	Output 3	Output 4	Output 5

 **WARNING** The Omni can be put to sleep by selecting that option in the User Menu. To wake the Omni, the following SID sequence is required: Left, Right, Left, Right. Note, this waking method only works if the Omni has been put to sleep via the User Menu. For that to work “Sleep 12V” parameter has to be turned off to allow the GyroSet™ Link to operate constantly. For safe operation of the chair NOW technologies does not recommend the

above-described scenario, instead please **install the Headrest Sensor** within the reach of the User that can act as an emergency stop as well. For more instructions, see the “Headrest and Headrest Sensor” section.

Please make sure that your R-Net configuration meets the following criteria:

- The correct SID port is configured as proportional.
- Sleep 12V parameter is set.
- User control is set.
- Drive, Acceleration and Deceleration settings are at a comfortable and safe level.

To avoid control problems when changing your seating position, we recommend modifying your setting in the Omni to allow control of the actuators only when the head is tilted either to the left or right side.

Setting up the IOM and the GyroSet™ Link

Setting up the IOM with the GyroSet™ Link should only be conducted by the distributor or a PGDT trained person.

Setting up the Dynamic Controls Linx DLX-IN500 and the GyroSet™ Link

Setting up the Dynamic Controls Linx DLX-IN500 with the GyroSet™ Link should only be conducted by the distributor or a Dynamic Controls trained person.

Setting up the Quantum Rehab Q-Logic 3 EX Enhanced Display or SCIM Module and the GyroSet™ Link

Setting up the Quantum Q-Logic 3 EX Enhanced Display or SCIM Module with the GyroSet™ Link should only be conducted by the distributor or a Q-Logic trained person.

Pairing instructions

In order to communicate securely, Bluetooth devices need to be paired.

This process might be familiar from using other Bluetooth devices.

Scenarios where pairing might be needed:

- *Phone - GyroSet™ Dongle:* Make sure the GyroSet™ Mouse application is running on your computer. When the phone offers the pairing code, type it in the pairing window that appeared on the screen of your computer.
- *Phone - GyroSet™ Cubo:* A 6 digit passkey will appear on the screen of GyroSet™ Cubo, enter into the input field that has just appeared on your phone.
- *GyroSet™ Cubo - GyroSet™ Dongle:* Make sure the GyroSet™ Mouse application is running on your computer. A 6 digit passkey will appear on the screen of GyroSet™ Cubo, enter the code in the input field that has just appeared on the screen of your computer.

Important:

- *Pairing GyroSet™ Dongle with your phone or GyroSet™ Cubo will require GyroSet™ Mouse (or GyroSet™ Drive) to run on the computer the Dongle is plugged into. This is to provide the Dongle with a platform through which it can communicate with your phone or the Cubo.*
- *If GyroSet™ Mouse (or GyroSet™ Drive) is not running on your computer, no Pairing pop-up window will appear in which you can input the pairing code provided by your phone or the Cubo and the Network cannot be set up. Moreover, Cubo may get stuck in this state of offering to pair with the Dongle and no other device can connect to it, until this is resolved.*
- *If you're adding a second GyroSet™ Dongle to your network, it too will need to be paired with your Cubo through the same process described above.*

Setting up the Vigo

The GyroSet™ Vigo was paired to your system at the factory.

Important: *For safety reasons, make sure to charge the Vigo with the provided USB charging cable before the first use.*

Pairing with your phone (optional: to receive calls and listen to auditory type entertainment)



WARNING *Using this function will drastically decrease the battery life of your Vigo from an average of 14 hours of run-time to 4-5 hours.*

1. In the mobile phone Settings, turn on Bluetooth. (iOS and Android: Settings > Bluetooth > On)
2. To pair Vigo with your mobile phone, press and hold the Vigo Multi-Function Button for 7 seconds, until you hear the word "Pairing" in the speaker. The Alert LED will flash alternating red and blue.
During this time the Vigo's battery state icon on the
3. In your mobile phone Settings, search for new Bluetooth devices.
4. Select "Vigo".
5. Once successfully paired, the Alert LED will stop flashing, and you will hear "Connected" spoken from the Vigo earpiece.

GyroSet™ LINK CONFIGURATION (Available for authorized dealers only)

If you are a user and you need to adjust the headset's settings, please contact your local distributor!

If you're one of our authorized dealers, please contact us at nowtech.hu/contact to request access to the software and the GyroSet™ Drive manual!

Personalize the driving experience

1. Download and install the GyroSet™ Drive software from our website.
After the installation, the GyroSet™ Drive application should start running automatically (depending on the operating system version and the setup of your computer).
2. Insert the GyroSet™ Dongle into the computer's USB port.
3. Turn on the Omni. This will turn on your GyroSet™ Link and your GyroSet™ Cubo.
4. In GyroSet™ Drive, go to Drive Profile. For further information, click the Help (?) icon in the top right corner or download the GyroSet™ Drive Help document .

The GyroSet™ Link translates the user's head movements into analog joystick sweeps. For that to function correctly all GyroSet™ Link parameters must be set according to the individual user's needs. The configuration of the GyroSet™ Link can be achieved through the GyroSet™ Drive application - available only for distributors - that provides an interactive Help and settings Wizard, which you can find by clicking on the question mark icon in the top right corner of the application on any page. The GyroSet™ Vigo can measure the tilting of the head in the four main directions, forward, backward, left and right.

Setting the driving parameters in the OMNI for safe and smooth acceleration

Speeds		HD
Maximum Forward Speed	80 %	
Minimum Forward Speed	10 %	
Maximum Reverse Speed	80 %	
Minimum Reverse Speed	10 %	
Maximum Turning Speed	80 %	
Minimum Turning Speed	10 %	
Maximum Forward Acceleration	15	
Minimum Forward Acceleration	15	
Maximum Forward Deceleration	20	
Minimum Forward Deceleration	15	
Maximum Reverse Acceleration	15	
Minimum Reverse Acceleration	10	
Maximum Reverse Deceleration	20	
Minimum Reverse Deceleration	15	
Maximum Turn Acceleration	25	
Minimum Turn Acceleration	25	
Maximum Turn Deceleration	30	
Minimum Turn Deceleration	30	
Power	100 %	
Torque	100 %	
Tremor Damping	50 %	
Fast Brake Rate	80	

1. Based on the factory default parameters, and according to the results of the test drive with a joystick, the assistant shall identify the highest speed values of the chair that enables the user to drive the chair safely:

1. Maximum Forward Speed
2. Maximum Reverse Speed
3. Maximum Turning Speed

2. It is recommended to set both acceleration and deceleration speeds to a relatively low value in order to avoid the swinging of the head. This could disturb the operation of the sensors.

- Maximum Forward Acceleration: 15-35
- Maximum Forward Deceleration: 20-40
- Maximum Reverse Acceleration: 15-35
- Maximum Reverse Deceleration: 20-40
- Maximum Turn Acceleration: 25-45

- Maximum Turn Deceleration: 30-40

3. The assistant shall validate the drivability of the chair by using the chair themselves. Twitch of the chair during acceleration, deceleration or especially driving forward can be caused by the swinging of the head. In this case, we recommend increasing the value of the Tremor Damping from zero step by step, until the chair is able to accelerate without twitches.

4. The end-user should validate the driving parameters by driving the chair with the GyroSet™ Vigo. The assistant shall modify the maximum speed values and the value of the Tremor Damping according to the user's needs.

5. It is recommended to create a copy of the final profile as a basis for other profiles. When for example the user needs a second profile for indoor driving, it is enough to use the copy of the outdoors profile and change only the maximum forward speed value and leaving the rest untouched.

The above-mentioned example values and ranges can greatly differ from user to user. It is recommended to always follow the above process when setting values to gain safe driving and smooth acceleration.

How to wear and drive with the GyrsoSet™ Vigo

How to wear the Vigo



1. Find a comfortable seating position for the user and adjust the headrest so that the Headrest Sensor is always in reach for the user (3-5 cm). Pushing the Headrest Sensor with the back of the head should always be an easy operation. Try to do that several times and adjust your chair/wheelchair's seating or headrest position if required.
2. Try the Vigo on the user's head. Adjust the headband in a way that it sits firmly on the top of the user's head, and they can wear it comfortably for hours. To ensure operational efficiency, adjust the Vigo on the head. The sensor should be placed approximately 3 cm from the movable parts of the user's face (corner of the eye, cheek, corner of the mouth, etc.)

Turn on the System (for assistants/carers)

1. To turn on the Vigo, press and hold the Multi-Function Button on the Vigo for 5 seconds. The Alert LED will flash 3 times, Vigo will vibrate once, and you will hear “Power on” spoken from the Vigo earpiece if it’s close enough to your ears.
2. Put the Vigo safely on the head of the user: place it on the user’s head, adjust the click sensor’s flexible tube as described in this Manual. The sensor should be placed approximately 3 cm from the movable part of the user’s face (corner of the eye, cheek, corner of the mouth, etc.)
3. Turn on the Omni. This will turn on the GyroSet™ Link and the GyroSet™ Cubo
4. You will see the Bluetooth icon of the Cubo flashing and a No device text.



5. The Cubo will recognize the Vigo and the text “Link Drive” will appear.



6. Ask the user to push the Headrest Sensor, and when she starts hearing the sounds, push it again before the sounds are over. This will activate the Drive mode and Deactivate again to finish the calibration process. At the end of the process, the Link will be in an inactive state.

For other status displays, please see the GyroSet™ Cubo System Status Feedback section in the Appendix.



WARNING *If you ever experience that the chair is not following your directions accurately, stop driving and recalibrate the system. Follow the directions above and put the Vigo on a stable and flat surface after step 5 until the calibration icon changes to a checkmark (usually 5-10 seconds).*

Driving and mousing with the GyroSet™ Vigo

Switch modes with the Vigo

The default mode after the turn-on process is inactive drive mode.

Drive mode

To start driving, give the Headrest Sensor a short-press with the back of the head (0-1 seconds).

Emergency stop/Leave driving mode:

Push the Headrest Sensor with the back of the head with a fast (faster than reversing) movement. The chair will react immediately to the push of the sensor.

The chair stops also when the head leaves the range set in the GyroSet™ Drive application and also when the user is making fast, seizure-like movements.

Enter the Omni menu:

When the driving mode is inactive, use a face-wink gesture to enter the menu of the Omni.

To be able to navigate in the menu, the head drive needs to be in active mode, please use the Headrest Sensor to activate navigation in the menu.



WARNING Please do not leave the Omni menu by the Exit option in the menu as this will cause you immediately driving the chair. Instead, deactivate the menu navigation first by using the Headrest Sensor and then switch to drive mode with a face-wink to continue driving.

Mouse mode

To use this function, a connected set of GyroSet™ Dongle and GyroSet™ Vigo is sufficient.

If a GyroSet™ Cubo is present in the network, the user can switch between 'drive mode' and 'mouse mode' by long-pressing the Headrest Sensor, as described below.

Plug the GyroSet™ Dongle in the computer's USB port.

The color of the LED will indicate whether the Dongle is communicating with GyroSet™ Cubo or Vigo.

In a network where a Cubo is present, mousing can be initiated by short-pressing the Headrest Sensor.

In case of a GyroSet™ Dongle and GyroSet™ Vigo only connection, you can start mousing by pressing the Vigo's Multi-Function button.

In this setup we advise users to disable the headset button in their phone settings or disconnect their smartphone from GyroSet™ Vigo, otherwise the Multi Function button will start mousing on the computer and start playing music (or answer calls) on your phone at the same time.

The mousing experience can be greatly enhanced by using the **GyroSet™ Mouse** application, which allows the user to adjust and fine-tune how the cursor reacts to head movements. Its toolbar unlocks other mouse functionalities, like the right-click and the middle-click, provides shortcuts for modifier keys (Ctrl/Cmd, Alt/Option, Shift) and the most used editing functionalities for easy access.

During mousing a face-wink is equivalent with the click of a mouse.

Details on how to use the software are included in its Help section (question mark in the top right corner).

For a detailed explanation of the GyroSet™ Dongle's LED colors, please see the GyroSet™ Dongle LED Status Feedback section in the Appendix.

Switching between available functions

If the user has a system of at least the following connected devices: GyroSet™ Link, GyroSet™ Cubo, GyroSet™ Vigo and GyroSet™ Dongle (i.e. the potential to use 'drive mode' or 'mouse mode'), then they can switch between the modes these devices provide (in this case driving and mousing) by long-pressing (1-5 seconds) the Headrest Sensor.

The GyroSet™ Cubo's screen will show the current mode (e.g.: LINK drive, MOUSE).

Resting

Tap the Headrest Sensor with the back of the head and hold it there for over 5 seconds. The Vigo Headset will give out a short vibration, signalling that the system entered rest mode, and GyroSet™ Cubo's screen will light up and stay that way for the duration of the rest. This function enables you to rest your head without the risk of accidentally initiating driving or mousing.

Two Dongle Support

In this release we support the use of 2 Dongles in one network. This option may be beneficial for users with two computers (e.g.: laptop and desktop computer, home computer and work computer). This way they don't have to carry their one dongle wherever they want to use the mouse function.

An extra GyroSet™ Dongle can be added to the network in GyroSet™ Toolbox under Network Management.

Switching between two active Dongles (if they are both in range) is as easy as switching between 'drive mode' and 'mouse mode' except in this case there are 2 'mouse modes' from which the user can choose, by long-pressing the Headerst Sensor.

Important: Please do not try to add more than 2 Dongles to one network. Our system can only manage a maximum of 2 Dongles safely in one network.

Drive with your Vigo

1. Imagine that your head is like a regular joystick.
2. Tilt your head (make sure not to turn as it has no effect) to the direction you wish to go. The tilt amount is proportional to the speed of the wheelchair's movement. Make slow, fluid and small movements with your head to avoid activating the emergency stop.
3. To come to a halt, move your head into the neutral position (into the dead-zone)
4. To stop driving press the Headrest Sensor.

For each drive session, a new neutral position can be selected, this helps in case the users change their posture.

Using the OMNI Menu

1. To avoid control problems when changing your seating position, we recommend modifying your setting in the OMNI to control the actuators only with head side tilts.
2. When the chair is not moving the GyroSet™ Vigo's click sensor (face wink) can be used to enter into the Omni Menu.
3. Activate the head drive - by tapping firmly the Headrest Sensor - to navigate the menu.
4. Your head will act as a joystick to help you go through all the available preferences.
5. Select menu items with tilting your head right as with a joystick, but make sure to return to the neutral position
6. Use the face wink gesture again to deactivate the Omni menu navigation.

Other GyroSet™ Vigo Functions:

Answer an incoming call

Short-press the Multi-Function Button to answer the incoming call.

End a call

Short-press the Multi-Function Button to end the current call.

Reject a call

Long-press the Multi-Function Button for 2 seconds to reject the incoming call.

Adjust the volume

Press “VOL+” to increase volume. You will hear “beep” from the GyroSet™ Vigo earpiece.
Press “VOL-” to decrease volume. You will hear “beep” from the GyroSet™ Vigo earpiece.

Play/Pause

Short-press the Multi-Function Button to play/pause the music.

Power off

To power off GyroSet™ Vigo, press and hold the Multi-Function Button for 5 seconds. The Alert LED will flash blue 3 times, and you will hear “Power off” spoken from the GyroSet™ Vigo earpiece.

Battery charging & battery level

Charging: Use the included USB cable for charging. The Alert LED will turn red while charging.

Charging time: 2 hours. When fully charged, the Alert LED will turn off.

Low battery: You will hear “Battery Low” spoken from the GyroSet™ Vigo earpiece.

Important: Please make sure to pay attention to the “Battery Low” warning signals from the Vigo. Depending on usage the Vigo will shut down after approx. 10 minutes from the first warning. Please make sure to put the Vigo on a USB charger as soon as the “Battery Low” warning has been announced. It is advised that users take a USB power bank with them when going outdoors.

Music streaming

Streaming audio is initiated and controlled by your mobile phone.

When a call rings, any streaming audio will automatically pause, to enable you to answer the call. When the call has ended, the streaming audio will resume.

Play/Pause: Click the Multi-Function Button once.

Previous song: Long-press “Vol+” for 2 seconds.

Next song: Long-press “VOL-” for 2 seconds.

GyroSet™ Vigo Product Specifications

1. Bluetooth operating range: Up to 10 meters (30 feet)
2. Talk time: 10 hours (only when used as a headset, not as Head Drive)
3. Audio playtime: 10 hours (only when used as a headset, not as Head Drive)
4. Standby time: 10 days
5. Charging time: 2 hours
6. Bluetooth version: 4.0
7. Bluetooth profile: Support HFP, HSP and A2DP
8. Charging: Micro-USB
9. Noise cancellation: Dual MEMS microphone technology



WARNING Do not press and hold the combination of the Power button and the Volume down (-) buttons. This will put the Vigo into DUT (service mode) which will render the Vigo unusable. In this state the Vigo cannot be turned off, you have to wait for the battery to deplete completely.

Appendix

GyroSet™ Vigo LED Indications:

Solid Red: Charging

No led while USB cable is attached to power: Fully charged

Flashing Red: Vigo's battery is low

Flashing Blue: Vigo is in pairing mode

Red, Green and Blue sequence: Vigo has just been turned ON

3 quick Red flashes: Vigo has just been turned OFF

LED flash blue once every 5 seconds: Vigo standby (without connecting to a phone)

LED flash cyan once every 7 seconds: Vigo working mode (connect to a phone) or playing music

LED double-flash cyan once every 3 seconds: incoming call, answer a call or dial-out

GyroSet™ Dongle LED Status Feedback

In normal mode:

Blinking blue light: Dongle is *not* connected to Vigo or Cubo

Continuous blue light: Dongle is connected to Vigo or Cubo

Continuous purple light: Dongle is connected and half-calibrated

Continuous cyan light: Dongle is connected and fully calibrated

Continuous red light: Protocol mismatch with Vigo. Vigo's Firmware is probably not up to date.

Yellow light: The reset button is being pressed

During Firmware update:

White light: when firmware update starts in Bootloader mode

Yellow light: during firmware upload

Green light (for a moment before Dongle restarts): at successful update

Red light: when the firmware upload process fails

Resetting GyroSet™ Dongle manually

In case you need to reset your Dongle manually, please follow these steps:

1. Gently insert a pin (e.g.:straightened paper clip) into the small hole found on the opposite end from the USB plug.

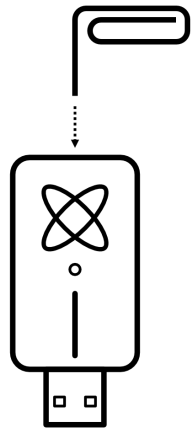

The pin has to be completely perpendicular to that face of the Dongle.

2. Press the pin in until you feel the click of a small button.
3. Press and hold this button for a few seconds while you plug in the Dongle.
4. The LED will signal that the reset button is being pressed, that is normal.
5. After releasing the button the Dongle will come alive with a blinking blue light, meaning it's not paired to any device (it's been reset).

GyroSet™ Link LED (GyroSet™ Logo) Indications:









Colour	Light pattern	Status
None	No	The device is turned off or in sleep
White	Breathing: fade in – fade out	The device is turned on, but there is no headset
Blue	Breathing: fade in – fade out	Connection to the headset established through RADIO and IDLE
Blue	Blinking	Connection to the headset established through RADIO and ACTIVE
Green	Breathing: fade in – fade out	Connection to the headset established through CABLE and IDLE
Green	Blinking	Connection to the headset established through CABLE and ACTIVE
Orange	Breathing: fade in – fade out	GyroSet™ Link is in Service Mode
Red	1 short high sound signal	System halted due to an error. Driving stopped
Blue	Rapid blinking	Waiting for centering the head (RADIO connection)
Green	Rapid Blinking	Waiting for centering the head (CABLE connection)



GyroSet™ Link Audible feedback:

Please note that you can mute/unmute all Link sounds by a short tap on the GyroSet™ logo.

	Description	Meaning
. -	one short and low sound followed by a longer and higher sound	Linked turned on
. -	one very short, lower sound, followed by a longer and a little bit higher sound	Start driving
. _	one very short higher sound followed by a longer and a little bit lower sound	Stop driving
— — —	one very long sound repeating continuously	Reversing
.	one short, high sound	Fifth down
.	one short, high sound (a bit lower than fifth down)	Fifth up
.	one very short sound of average height	Set center/waiting
.	one very short beep sound	Mute







GyroSet™ Cubo system status feedback

	Description	Meaning
	An arrow is running around the Bluetooth icon in a counterclockwise direction. A circle and a “no device” label are visible.	The system lost its binding with the GyroSet™ Vigo and is looking for the first GyroSet™ Vigo it is able to find.
	The Bluetooth icon is flashing. A circle and a “no device” label are visible.	The system is bound to, but doesn't have a connection with the GyroSet™ Vigo and is looking for it.
	The Bluetooth icon is highlighted. The clock hand in the circle is flipping. A “LINK Drive” label is visible.	The system is connected and is being calibrated. To enable the system to finish calibration, the GyroSet™ Vigo has to be in a stable, resting position.
	The Bluetooth icon is highlighted. A checkmark icon is highlighted. A “LINK Drive” label is visible.	The system is connected and ready for driving, but the drive mode is passive.
	The Bluetooth icon is highlighted. A checkmark icon is highlighted. The “LINK Drive” label is highlighted.	The system is connected and it is in active drive mode.
	The entire screen lights up inverted.	The system is switching between modes in the channel map. (e.g. LINK Drive → MOUSE)
	The Bluetooth icon is highlighted. A checkmark icon is highlighted. A “MOUSE” label is visible.	The system is connected and ready for mousing, but the mouse mode is passive.
	The Bluetooth icon is highlighted. A checkmark icon is highlighted. The “MOUSE” label is highlighted.	The system is connected and it is in active mouse mode.

	<p>The Bluetooth icon is highlighted. A checkmark icon is highlighted. A "LINK Drive" label is blinking upon pressing the Headrest Sensor.</p>	<p>Driving cannot be initiated, GyroSet™ Link can't communicate with GyroSet™ Cubo.</p>
	<p>The Bluetooth icon is highlighted. A checkmark icon is highlighted. The "MOUSE" label is blinking upon pressing the Headrest Sensor.</p>	<p>Mousing cannot be initiated, GyroSet™ Vigo can't communicate with GyroSet™ Cubo.</p>

Other important display messages and items:

- *"LINK connected Protocol error"* - means that GyroSet™ Link's Firmware is not compatible with Cubo's. Update the GyroSet™ Link via the GyroSet Toolbox mobile application!
- *"VIGO connected Protocol error"* - means that GyroSet™ Vigo's Firmware is not compatible with Cubo's. Update the GyroSet™ Vigo via the GyroSet Toolbox mobile application!
- We've added a new GyroSet™ Vigo headset battery status icon to the Cubo display, which has the following states:

	Description	Meaning
	<p>The battery icon is blinking between an empty and a full state.</p>	<p>Reading battery state - please, wait about 30 sec!</p>
	<p>The battery icon is blinking between a ONE bar and an empty state.</p>	<p>The Headset's battery is low - please, charge your Vigo ASAP!</p>
	<p>The battery icon is showing TWO bars.</p>	<p>The Headset's battery is at 50%.</p>
	<p>The battery icon is showing THREE bars.</p>	<p>The Headset's battery is at 70%.</p>
	<p>The battery icon is showing FOUR bars.</p>	<p>The Headset's battery is at 90%.</p>
	<p>The battery icon is showing FIVE bars.</p>	<p>The Headset's battery is FULL.</p>
	<p>The battery icon is cycling through all states ending with the plug icon.</p>	<p>The Headset is charging.</p>



WARNING If your GyroSet™ Vigo has been manufactured before 2021 (you can tell from the first set of numbers on the serial number, e.g. **2019-41-000-0017**), its battery status displayed by GyroSet™ Cubo may not be completely accurate. The 3rd, 4th and 6th battery states from the table above may not get displayed.

Resetting GyroSet™ Cubo manually

In case you need to reset your Cubo manually (e.g. asked to do so by Customer Support) please follow these steps:

1. Insert a pin (e.g.: straightened paper clip) into the small hole found on the bottom of the device.

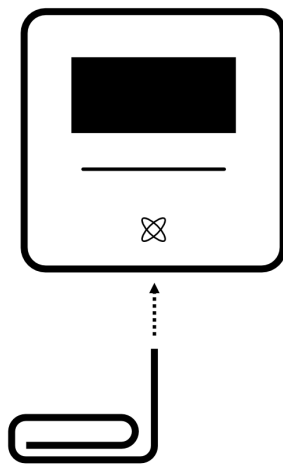

The pin has to be completely perpendicular to the bottom of the device.

2. Press the pin in until you feel the click of a small button.
3. Press and hold this button for a few seconds until you see the message “Factory reset restart CUBO”.
4. At this point you can either restart Cubo manually or just wait for it to restart automatically.
5. The Cubo will display the following screen, meaning it's not paired to any device (it's been reset).



SPECIAL SAFETY CHECKLIST

Please make sure that the following criteria are met before trying to drive the wheelchair with the GyroSet™ Drive System:

- Understanding of the intended use of the GyroSet™ Cubo and the GyroSet™ Vigo by getting familiar with this User Manual.
- The adjustment of the headrest: The user must be able to reach the Headrest Sensor at any time to be able to activate it.
- The intended direction of movement must be set by using GyroSet™ Drive.
- The user's head movement range must be set by using GyroSet™ Drive.
- Out of operation range for the faint detection threshold must be set using GyroSet™ Drive.
- Tremor filter must be set using GyroSet™ Drive.
- Click sensor functions and parameters must be set using GyroSet™ Drive.
- Click sensor long-press maximal timeout must be set using GyroSet™ Drive.
- Centre mode and parameters must be set using GyroSet™ Drive:
 - Please make sure to check if the center mode is set to "Countdown" in GyroSet™ Drive. If yes, the "Timeout" has to be set.
- The maximum speed, acceleration, deceleration of the head drive profile of the wheelchair controller must be adjusted:
 - Settings of the controller must be administered specifically trained and authorized personnel.
 - Acceleration and deceleration settings of the wheelchair shall not cause inertia on the user's head that the user cannot compensate.
 - Maximum speed must always be in accordance with the local regulations.
- The service network must be used only for the time when changes are made to the personal drive profile.
- The user should avoid:
 - Environments with extreme radio interference when driving wirelessly as it may cause the wheelchair to stop if it receives no signals.
 - Environments with extreme temperatures. The working temperature of GyroSet™ Link is between -20°C and 50°C .
 - The user shall be aware of the fact that the GyroSet™ Link must be selected by using the Headrest Sensor for control with the GyroSet™ Vigo.
- The user must be trained and know how to handle the center detection (jump to center).

- ❑ In case the mode is set to countdown, the user's head shall be motionless in a neutral position after activating the drive function for a few seconds until the countdown stops.
 - ❑ In case the mode is set to automatic, the drive won't start until the head is put into a motionless state for less than a second.
- ❑ Be aware that the GyroSet™ Vigo acts as a joystick within the R-Net control system:
 - ❑ By programming the wheelchair controller, various functions can be tied to "fifth button" presses, in this case, the click sensor of the GyroSet™ Vigo.
 - ❑ When the fifth button's long-press timeout is set to a smaller value on the R-Net than on the GyroSet™ Link the click sensor can turn the chair into sleep mode.
 - ❑ In case the fifth button function is programmed so that the User can access the Omni menu, the GyroSet™ Vigo can be used to navigate within the menu using head gestures similar to the controller's joystick.
 - ❑ In case the fifth button function is programmed so that the User can control actuators, the GyroSet™ Vigo can be used to move the actuators using head gestures similar to the controller's joystick.
- ❑ After the drive mode is initiated, a distinguishable audio feedback can be heard.
 - ❑ The chair will move according to the head movements and the profile settings of the GyroSet™ Link and the controller.
 - ❑ The chair will move until the function is deactivated or failure is detected. The chair stops immediately if a failure is detected, a cable is unplugged or wireless signal is lost.
 - ❑ The chair can be stopped while in drive mode by moving the user's head to the initial neutral position.
- ❑ In case the center of driving feels off compared to the initial center, the user shall stop and reinitiate drive, taking on a new center/neutral position.
- ❑ That depletion of the GyroSet™ Vigo's battery will cause the chair to stop.
 - ❑ The GyroSet™ Vigo's battery must be charged on a daily basis.
- ❑ If the GyroSet™ Vigo falls off, the chair stops.
- ❑ A sudden backward movement of the head inside the turning dead zone will force the system to execute an emergency brake of the chair.
- ❑ In case the user's head reaches the maximum of the range of operation the sweep of the head joystick is at maximum.
- ❑ If the user's head reaches the safety zone in any direction the chair will stop.
- ❑ If the user's head is in the range of the center dead zone the chair won't move or it will stop.
- ❑ If the cable connecting GyroSet™ Link and PGDT Omni or IOM equipped wheelchair gets damaged and/or short-circuited the chair will stop. Short circuits on analog lines are handled by R-net's safety system, because neither GND nor VCC are accepted as analog control voltages.
- ❑ User or carer intervention may be required when experiencing unusual behavior. The Safety switch button needs to be pressed or the Headset tilted to the safety limit to induce stopping. Tremor filter can be used to compensate for vibrations.

- ❑ If there is no BLE data stream available, GyroSet™ Cubo gives a stop command to GyroSet™ Link which is passed on to the chair, and the chair stops immediately.
- ❑ When in doubt, just remember, the chair can be stopped immediately by tilting the Headset to the previously set safety limits!



WARNING The microcontroller is protecting the firmware with built-in hardware fuses, any attempt on reading or modifying the content of the flash will fail. All user-related variables are encrypted, any attempt on gaining access to secure data will erase the chip content.

WARRANTY

NOW technologies Ltd. provides two year's full warranty on the products. This warranty covers any defects in materials or workmanship, with the exceptions stated below:

Faults resulting from the installation by an unqualified person. Any problem that is caused by abuse, misuse, extreme water damage, or extreme weather are not covered. Also, consequential and incidental damages are not recoverable under this warranty.

Revision History

Revision number	Changelog	Date of release
01	Original content	30 November 2019
02	Updated to pre-final release	10 May 2020
03	Minor updates	01 February 2021
04	Update to final release	25 June 2021

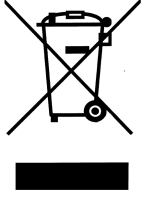

EUROPEAN UNION – DISPOSAL INFORMATION

The symbol above means that according to local laws and regulations your product and/ or its battery shall be disposed of separately from household waste. When this product reaches its end of life, take it to a collection point designated by local authorities. The separate collection and recycling of your product and/or its battery at the time of disposal will help conserve natural resources and ensure that it is recycled in a manner that protects human health and the environment.

EU COMPLIANCE STATEMENT

NOW technologies Ltd. hereby declares that this wireless device is in compliance with the essential requirements and other relevant provisions of the R&TTE Directive and Radio Equipment Directive 2014/53/EU, as applicable. NOW technologies' EU representative is NOW technologies Ltd. 18. Reáltanoda street, Budapest, 1053 Hungary.

The GyroSet™ Drive components contain modules with the following FCC IDs:

GyroSet™ Link:

FCC ID: W70MRF24J40MDME

GyroSet™ Cubo:

FCC ID: 2AC7Z-ESPWROOM32D

GyroSet™ Vigo:

FCC ID: 2AFKV-VIGO

GyroSet™ Dongle:

FCC ID: SH6MDBT50Q

www.nowtech.hu



RoHS DECLARATION OF CONFORMITY

We hereby declare that our products are compliant to RoHS Directive 2011/65/EU of the European Parliament and the Council from 08/06/2011 on the restriction of the use of certain hazardous substances in electrical and electronic appliances.

NOW technologies Ltd. herewith declares that all of our products are manufactured in compliance with RoHS.